



.....1

.....5

1.1	.....	5
1.2	.....	9
1.3	.....	10
1.4	.....	11
1.5	.....	15
1.6	.....	21
1.7	.....	22

.....23

2.1	.....	23
2.2	.....	56
2.3	.....	62
2.4	.....	70
2.5	.....	71
2.6	.....	72
2.7	.....	73
2.8	.....	78

.....79

3.1	.....	79
3.2	.....	86
3.3	.....	115
3.4	.....	116
3.5	.....	116

.....143

4.1	.....	143
4.2	.....	149
4.3	.....	185

.....192

5.1	.....	192
5.2	.....	197
5.3	.....	197
5.4	.....	203

.....207

6.1	.....	207
6.2	.....	208
6.3	.....	210
6.4	.....	211
6.5	.....	215

---

6.6	.....	218
	.....	<b>220</b>
7.1	.....	220
7.2	.....	220
	.....	<b>222</b>
8.1	.....	222
8.2	.....	225
8.3	.....	226
	.....	<b>228</b>
9.1	.....	228
9.2	.....	236
9.3	.....	237

- 
- 1
  - 2
  - 3
  - 4 2010
  - 5
  - 6

- 1.7-1
- 2.1-3
- 2.1-4
- 2.2-1
- 2.2-2
- 3.1-1
- 3.2-1
- 3.2-2
- 3.5-1
- 4.2-1
- 4.2-3
- 4.2-4
- 5.1-1
- 5.1-2
- 5.1-3
- 5.1-4
- 5.3-1



---

1

1953

100

6000

1

10%

"

"

600

3

2

400

— —

5

"

"

— —

"

"

2001 11



---

12

12

3

2019 3 26

2019

2019 5 27

[2019]6

2019

66 t/a

2019

1

4

1

2

---

3

4

6

1

2

3

GB8978-1996 4

GB20426-2006 1 2

DB41/ 2087—2021 2 3

4

GB20426-2006 4

GB3096 2008 2

4

5

---

# 1.1

## 1.1.1

- (1) 2014 4 24 2015  
1 1
- (2) 2016 7 2  
2016 9 1 )
- (3) 2015 8 29 2016  
1 1
- (4) 2017 6 27  
2018 1 1
- (5) (1996 10 29 1997  
3 1 )
- (6) (2016 11 7  
)
- (7) (2009 08 27 )
- (8) (2010 12 25 )
- (9) 2012 7 1
- (10) 2023 4 1
- (11) 682  
2017 7 16 2017 10 1
- (12) 2016 3 29  
13 2017 12 1  
2018 3 1

---

14

2015 4 24

15

2022 10 30

2023 4 1

### 1.1.2

(1)

2016 7

(2) (2024 )

(3) 2007 46

(4)

(5) 44

2017 9 1

1 2018 4 28

6 2016

4

(7) [2005]109

8

[2015]107

9

2016 27

10

2016 245

11

2017 4

---

	12			2007	80
2007	11	23			
	13				10
2015	3	1			
	14				
			2007	1456	
	15				2024
2024	7				
	16				2024
2024	7				
	17				2024
2024	7				
	18				
		2023			
			2023	14	
	19				
					[2018]209
	20			4	2019
1	1				
	21			2021	10 8
	22		2022	6	

---

### 1.1.3

1		2022	3	1
2				[2021]45
3				
		2021	44	
4				
[2022]13				
5				[2023]1
2023	5	3		
6				
		2019	125	
7				
		2021	206	
8				2016 23

### 1.1.4

1	•	HJ2.1-2016
2	•	HJ2.2-2018
3	•	HJ2.3-2018
4	•	HJ2.4-2021
5	•	HJ610-2016
6	•	HJ19-2022
7	•	HJ964-2018
8		HJ169-2018
9		HJ651-2013
10		GB18599- 2020
11	—	HJ619-2011

---

## 1.1.5

1

2023 3

2

2023 2

3

2010 9

4

## 1.2

### 1.2.1

### 1.2.2

1

2

3

---

4

### 1.2.3

## 1.3

### 1.3.1

1.3-1

1.3-1

		-1S		-1S	-1S	-1S	-1S	-1L	-1S					-1S	
		-1S	-1S		-1S	-1S	-1S	-1S	-1S					-1S	
		-1S			-1S					+1S					+1S
		-1S	-1S		-2S		-1S			+2S		+1L		-1S	+1S
		-1L				-1L					-1L		-1L		
			-1L												
					-2L								-1L		
													-1L		
				-1S		-1S	-1S	-1S			-1S				
		+1L	+1L		+1L	+1L		+1L			+1L		+1L	+1L	
					3		2		1		L			S	

### 1.3.2

1.3-2

1.3-2

		TSP PM <sub>10</sub> PM <sub>2.5</sub> SO <sub>2</sub> NO <sub>2</sub> CO O <sub>3</sub>	
	SS COD BOD <sub>5</sub> NH <sub>3</sub> -N pH	pH	
		pH	
		K <sup>+</sup> Na <sup>+</sup> Ca <sup>2+</sup> Mg <sup>2+</sup> CO <sub>3</sub> <sup>2-</sup> HCO <sub>3</sub> <sup>-</sup> Cl <sup>-</sup> SO <sub>4</sub> <sup>2-</sup>	
	A L <sub>Aeq</sub>	L <sub>Aeq</sub>	
		pH	

## 1.4

### 1.4.1

1	GB3095-2012
2	GB3838-2002 IV
	GB5084-2005
3	GB/T14848-2017
4	GB3096-2008 2
5	GB5084-2005
6	
	GB15618-2018

2527-2023 2

1.4-1

1.4-1

	GB3095-2012	SO <sub>2</sub>	<sup>3</sup>	24h	150
			<sup>3</sup>	1h	500
		TSP	m <sup>3</sup>	24h	300
		PM <sub>10</sub>	<sup>3</sup>	24h	150
		PM <sub>2.5</sub>	<sup>3</sup>	24h	75
		CO	mg/m <sup>3</sup>	1h	10
			mg/m <sup>3</sup>	24h	4
		O <sub>3</sub>	<sup>3</sup>	1h	200
			<sup>3</sup>	8h	160
		NO <sub>2</sub>	<sup>3</sup>	24h	80
			<sup>3</sup>	1h	200

GB3838-2002  
IV

		Mn		1
				2
	GB3096-2008 2		dB(A)	60
			dB(A)	50
			mg/kg	65
			mg/kg	38
			mg/kg	60
			mg/kg	800
			mg/kg	5.7
			mg/kg	18000
			mg/kg	900
			mg/kg	2.8
			mg/kg	0.9
			mg/kg	37
		1, 1-	mg/kg	9
		1, 2-	mg/kg	5.0
		1, 1-	mg/kg	66
		-1, 2-	mg/kg	596
		-1, 2-	mg/kg	54
			mg/kg	616
		1, 2-	mg/kg	5
		1, 1, 1, 2-	mg/kg	10
		1, 1, 2, 2-	mg/kg	6.8
			mg/kg	53
		1, 1, 1-	mg/kg	840
		1, 1, 2-	mg/kg	2.8
			mg/kg	2.8
		1, 2, 3-	mg/kg	0.5
			mg/kg	1.43
			mg/kg	4
			mg/kg	270
		1, 2-	mg/kg	560
		1, 4-	mg/kg	20
			mg/kg	28
			mg/kg	1290
			mg/kg	1200
		+	mg/kg	570
			mg/kg	640
			mg/kg	76
			mg/kg	260
		2-	mg/kg	2256
		[a]	mg/kg	15
		[a]	mg/kg	1.5
		[b]	mg/kg	15
		[k]	mg/kg	151
			mg/kg	1293
		[a, h]	mg/kg	1.5
		[1, 2, 3-cd]	mg/kg	15
			mg/kg	70
	GB36600-2018			

			mg/kg	0.8
			mg/kg	1.0
			mg/kg	20
			mg/kg	240
	GB15618-2018	pH	mg/kg	350
	7.5		mg/kg	100
			mg/kg	190
			mg/kg	300

## 1.4.2

1 GB20426-2006 1

2 3

GB8978-1996 4

DB41/ 2087—2021 2 3 4

2

GB12523-2011

GB12348-2008 2

3 GB20426-2006 4

5

4

GB18599-2020 GB 18597-2023

## 1.4-2

### 1.4-2

		5	1.0mg/m <sup>3</sup>
	GB20426-2006		80mg/m <sup>3</sup>
			98%
	GB8978-1996	4	pH 6 9
			COD <sub>Cr</sub>

—2021	2	3	4	DB41/ 2087	SS	70mg/L	
						15mg/L	
					BOD <sub>5</sub>	20mg/L	
						10mg/L	
					COD	50mg/L	
						5.0mg/L	
						15 mg/L	
						0.5 mg/L	
					pH	6 9	
						30mg/L	
						10 mg/L	
						3.0 mg/L	
						0.1 mg/L	
						0.5 mg/L	
						5.0mg/L	
						3.0 mg/L	
						0.5 mg/L	
						1.5 mg/L	
						0.1 mg/L	
						1000 mg/L	
						0.01 mg/L	
						0.02 mg/L	
						0.1 mg/L	
						0.1 mg/L	
	0.2 mg/L						
	5.0mg/L						
2	GB20426-2006	1	pH	6~9	mg/L		
			COD <sub>Cr</sub>				
			SS				
				5			
				6			
				4			
				0.5			
				0.1			
				5			
2	GB12348-2008			60	dB A		
				50			
GB 18597-2023				GB18599-2020			

1.5

1.5.1

1

547m<sup>3</sup>/h 13128m<sup>3</sup>/d

579m<sup>3</sup>/h 13896m<sup>3</sup>/d 860m<sup>3</sup>/h

+ + 2

2 6 +1

HJ2.3-2018

1.5-1

	Q/ m <sup>3</sup> /d		W/	
		Q 20000	W 600000	
A	Q<200	W<6000		
B	—			

Q 12524m<sup>3</sup>/d Q 6.48m<sup>3</sup>/d Q

12530.48m<sup>3</sup>/d W 67080

2

HJ2.2-2018

---

$$P_i = \frac{C_i}{C_{0i}} \times 100\%$$

$P_i$        $i$        $P_i$        $i$   
 10%       $D_{10\%}$        $P_i$   
 $P_i$        $i$       %  
 $C_i$        $i$        $\text{mg/m}^3$   
 $C_{0i}$        $i$        $\text{mg/m}^3$

1.5-2

	$P_{\max}$
	$\max$ 10%
	$P_{\max}$ 1%

15

$P_{\max}=0.053\%$   $D_{10\%}$  0m

(HJ2.2-2018)

3

HJ2.4-2009

GB3096—2008

1 2

3dB(A) 5dB(A)

GB3096-2008

2

5dB(A)

---

4

1.5-3

	2	2-20km <sup>2</sup> 50-100km	2

2hm<sup>2</sup>

0.80km<sup>2</sup>

0.80km<sup>2</sup>

(HJ19-2022)

5

1

HJ610-2016

III

2

II

III

---

1.5-4

3

1.5-5

1.5-5 II

III

1.5-4

HJ619-2011

6

HJ169-2018

0.00048 1

I

1.5-6

	+			a
a				A

7

3.13 2.5

1.8m

<1g/kg

5.5<pH<8.5

"

"

表 1.5-7

生态影响型土壤评价等级判定表

/	I	II	III	
			/	

"

"

23hm<sup>2</sup>

50hm<sup>2</sup>

" " 3

1.5-7

表 1.5-8

污染影响型土壤评价等级判定表

	I			II			III			

## 1.6.2

## 1.7

1.7-1      1.7-1

1.7-1

		m		/				
		50m	112 415		GB3095-20 12			
		530m	78    320					
		340m	150 611					
		1000m	960 3690					
		1500m	217 860					
			2.8km			GB3838-20 02    IV		
			13km					
						GB/T14848 —2017		/
						/		/
	1	200m						
	2	200m						

---

## 2.1

### 2.1.1

#### 2.1.1.1

2020 9 14  
C4100002009051120019924 2020 10 31 2022 10  
31 30  
3.0km 1.8km 5.2787km<sup>2</sup> 1  
+140 50m  
1  
60m 20m  
330 73m 1 -50 +140m  
0 9.09m 4.25m  
547m<sup>3</sup>/h,  
579m<sup>3</sup>/h  
2021 [2021]70  
1.21m<sup>3</sup>/t 1.22m<sup>3</sup>/min  
1  
19.5 21 21 25  
2020 12 31 3136.94  
2325 811.94  
255.49 506.95 49.5

2.1-1

2.1-1

		205.5m 4	4.5m	2JK-3× 1.5E	
		430m	4.5m	2JK-2.5× 1.5E	
		196m	3m		
		1 FBCDN <sub>0</sub> 18 YBFe315S-18		26.5 56.6m <sup>3</sup> /min	
		1 BD54-DN <sub>0</sub> 18 YBFe315S-18		26.5 56.6m <sup>3</sup> /min	
		VHY-12/7-KB	1		
		× 3	1	JG10D 55× 3	1 D280 43
		4	SSM—55× 5	6DA—8× 3	3 D600—55× 5
			2		
			25.44hm <sup>2</sup>		
			6000m <sup>2</sup>		
			0.25hm <sup>2</sup>	1 t	
		Y008	2.8km	300m	
		1100	1100		
			2	250kW	
				500kW	
			6.48m <sup>3</sup> /d		
			1.8 t/a		
			58.3t/a		

		1	3	2	1	2.5	
					1		

### 2.1.1.2

1

1

552m<sup>3</sup>/h( 2013 )

2 2 1

35×8×3 840m<sup>3</sup> 1 450m<sup>3</sup>/h 2

20×8×3 480m<sup>3</sup> 2 410m<sup>3</sup>/h

860 m<sup>3</sup>/h 550m<sup>3</sup>/d

54m<sup>3</sup>/d 12164m<sup>3</sup>/d

2024 7 3 -4

2.1-2

COD

17mg/L SS 22mg/L 0.24mg/L

GB20426 2006 1 2

GB5084-2005

2

6.48m<sup>3</sup>/d

2024 7 3 -4

2.1-3

COD 23mg/L SS 14mg/L

---

5.59mg/L

DB41/2087-2021

2

3

4

**2.1-2**

mg/L

		pH	COD	SS	NH <sub>3</sub> -N	BOD						
		6 9	50	50	15	/	10	/	4	/	10	
		5.5 8.5	200	100	/	100	2	1000	/	4000	10	
		8.3 8.6	343 505	74 95	0.708 0.795	120 154	0.25 0.29	406 540	0.061 0.067	6000 8400	1.11 1.44	
		8.3 8.5	12 17	12 22	0.209 0.240	3.5 5.1	0.18 0.19	414 519	0.015 0.019	310 420	0.88 0.98	
1					20426 2006		1 2 2				GB5084 2005	
	3				GB8978 1996 4		4					

**2.1-3**

mg/L

		pH	COD	NH <sub>3</sub> -N	BOD <sub>5</sub>	SS			
		6 9	40	3.0	10	30	0.4	5	1000
		7.6 8.3	39 51	9.88 11.5	13.2 16.6	47 71	1.13 1.44	1.02 1.31	3.6 4.7 × 10 <sup>6</sup>
		7.7 8.3	15 23	2.50 2.79	6.1 7.3	9 14	0.26 0.32	0.50 0.75	6.3 8.4 × 10 <sup>2</sup>
		/	/	/	/	/	/	/	/
1.					DB41/2087-2021 2		3 4		

3

1

COD 2017 9

2023 1 ~2024 7

2.1-4 2023 1-2024 7

mg/L pH

	t	COD mg/L	COD t		t	COD mg/L	COD t
2023 1	158242.28	9.75	1.40	2024 1	578355.58	14.45	8.63
2023 2	225770.27	7.65	1.76	2024 2	494417.86	17.43	8.46
2023 3	262079.47	5.91	1.57	2024 3	364549.35	14.26	5.12
2023 4	380477.96	6.84	2.60	2024 4	226423.39	13.18	3.10
2023 5	446113.92	6.34	2.83	2024 5	294450.65	15.73	4.69
2023 6	421343.62	7.99	3.34	2024 6	157036.25	15.04	2.33
2023 7	382020.03	12.8	4.89	2024 7	428509.06	9.01	3.93
2023 8	471254.39	10.28	4.84				
2023 9	641323.47	10.04	6.44				
2023 10	787080.23	11.66	9.18				
2023 11	690093.08	14.00	9.66				
2023 12	667942.69	16.65	11.12				
	5533741.41		59.63		2543742.14		36.26
	40434.84	8.35			363391.73	14.16	5.18
	787080.23	16.65	11.12		578355.58	17.43	8.63
	158242.28	5.91	1.40		157036.25	9.01	2.33
DB41/ 2087 —2021	-	40		DB41/ 2087 —2021	-	40	
GB3838-2002	-	20		GB3838-200 2	-	20	

2022 1 ~2024 7

COD

5.91~16.65mg/L

COD

DB41/2087-2021

2

4

GB3838-2002 III

2023		553.37	m <sup>3</sup> /a		COD
8.35mg/L	COD	59.63t/a			
2				2024	7 3 -4
,	2.1-5	553.37	m <sup>3</sup> /a		COD
8.35mg/L	COD	59.63t/a			
	COD SS			15.33mg/L	13.83mg/L
2023		553.37	m <sup>3</sup> /a		COD SS
84.85t/a	76.55t/a				
					300m
Y008		2.8km			
13km				IV	
				2.1-1	

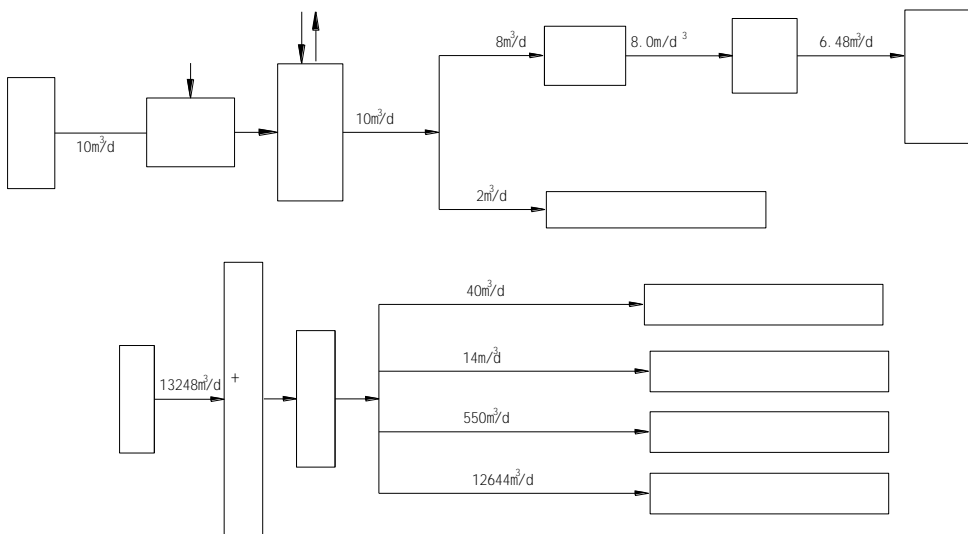

2.1-1

2.1-5

mg/L

	pH	COD	SS	NH <sub>3</sub> -N	BOD				MPN/L	
	6-9	50	50	15	/	10	/	/	/	10
	5.5-8.5	200	100	/	100	2	/	/	4000	10
III	6-9	40	30	3.0	10	5.0	0.4	12	1000	3.0
	8.3-8.7	12-19	11-16	0.502-0.581	4.2-5.7	0.19-0.20	0.13-0.16	2.38-2.74	480-620	0.53-0.77
	8.52	15.33	13.83	0.54	5.10	0.20	0.15	2.56	547	0.64
1	20426 2006				1	2	2	GB5084 2005		
3	GB8978 1996			4	4	III		DB41/2087-2021		
	2	3	4	5						

---

2

1

6000m<sup>2</sup>

40000t

2500m<sup>2</sup>

10000t

2023 6 16

2.1-6

					m <sup>3</sup> /h
		mg/m <sup>3</sup>	mg/s	kg/h	
(DA001)	2023. 6. 16	7.4	21.39	0.077	1.04× 10 <sup>4</sup>
	2023. 6. 16	8.4	23.89	0.086	1.02× 10 <sup>4</sup>
	2023. 6. 16	7.6	21.94	0.079	1.04× 10 <sup>4</sup>
		7.9	22.5	0.081	1.03× 10 <sup>4</sup>
	GB20426-2006	80			
		10			

2.1-7

		( $\mu\text{g}/\text{m}^3$ )		
	2023. 6. 16	308		
	2023. 6. 16	291		
	2023. 6. 16	319		
1	2023. 6. 16	552		
	2023. 6. 16	539		
	2023. 6. 16	494		
2	2023. 6. 16	507		
	2023. 6. 16	545		
	2023. 6. 16	527		
3	2023. 6. 16	498		
	2023. 6. 16	518		
	2023. 6. 16	512		
		254		
	GB20426-2006	1000		

2

3

1

1

3

2.18

		dB(A)	
1		96	
2		85	
4		75 82	
5		95	
6		75	
7		86	

2023 6 16

2.1-8

GB12348 2008 2

2.1-9

[dB A ]

		L <sub>Aeq</sub> [dB(A)]				GB3096-2008 2
2023.6.1		53	54	52	52	60
6		44	43	41	42	50

4

1

---

1.8 t/a

1

2023 11 10

HJ298-2019

HJ/T299-2007

mg/L pH

2.1-10

	0.28	0.05		0.09	0.28	
	5	0.1	5	1	15	5
						pH
	0.24	3.71			1.06	6.5
	100	100	5	5	100	/

GB5085.3-2007

2023 11 10

HJ/T20-1998

HJ557-2010

16

NY/T 1121.16

---

mg/L pH

2.1-11

	0.21				0.35		0.37	1.42	
	0.5	0.05	1.0	0.1	1.5	0.5	0.5	2.0	1.0
			pH						
		0.32	7.3	14	4L	0.16	0.14	1.6g/kg	
	0.5	10	6 9	100	70	0.5	10	2 g/kg	

GB8978-1996

pH 6 9

1.6% 2%

GB18599-2020

2

2020 63

2022 8

16

---

<b>2.1-12</b>	<b>Bq/g</b>		
\	$^{238}\text{U}$	$^{232}\text{Th}$	$^{226}\text{Ra}$
	0.040	0.079	0.055
	0.025	0.042	0.035

1 / Bq/g

2

58.3t/a

5

DZH2-1.25

DZH2-1.0

1

2019

SSDR-2100/WB

HFC-134a

75

---

6

1

5.3-1

4.5km<sup>2</sup>

2.1-2

6m

3m

2

1

100-300m

3

1.5km

0.1 2.3m

750m

---

0.01 2.30m

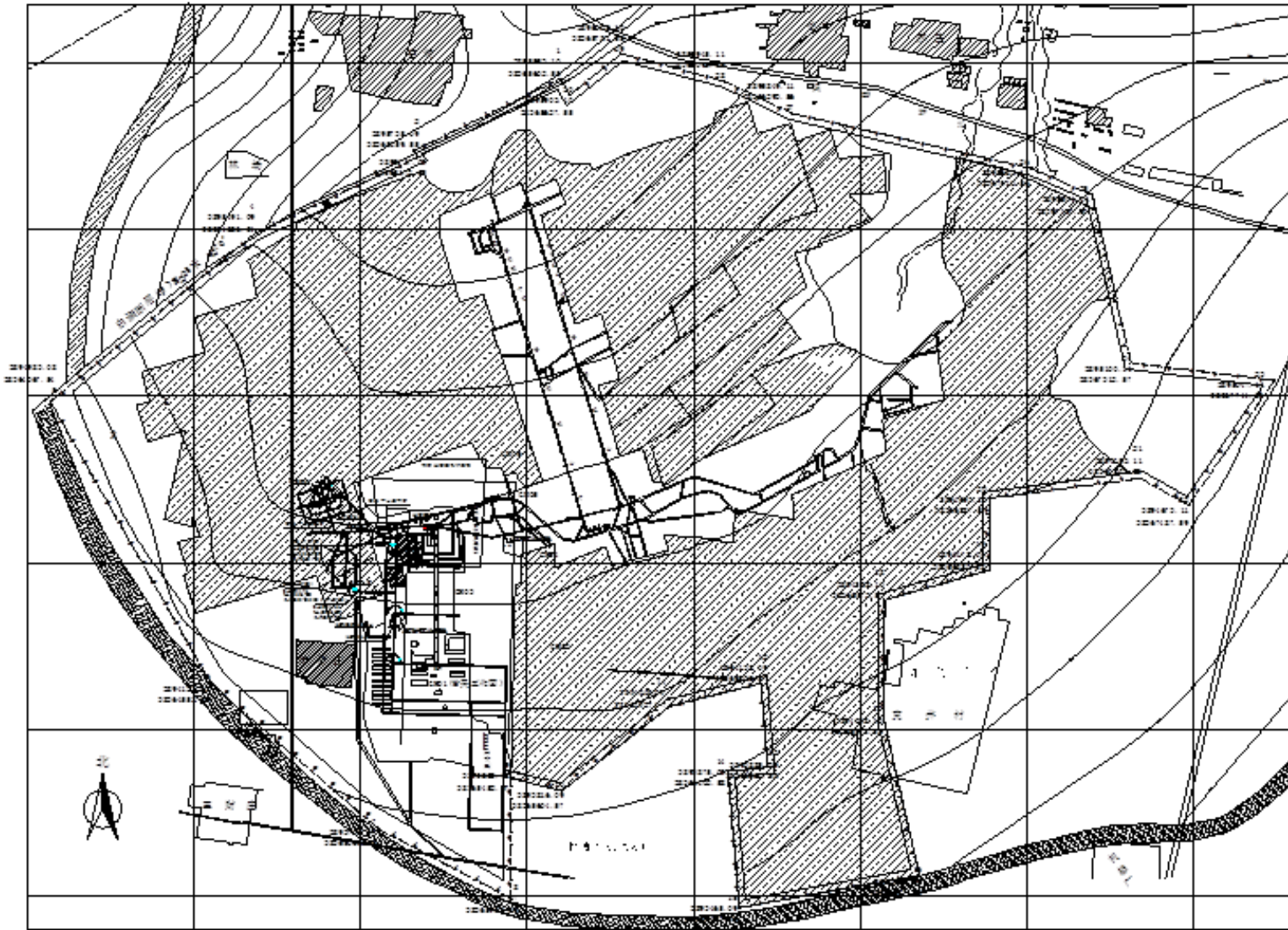

2.1-2

### 2.1.1.3

#### 2.1-13

	-	400	2.5 400 2025 6
			2024 12
			2025 6
		4.5m <sup>3</sup>	2025 6
			2025 6
		80m <sup>2</sup>	2025 6
	8	3000m <sup>2</sup>	2025 6
	8000	30	2024 4
	40	3.2hm <sup>2</sup>	6-7
			2024 12
			2024 12

---

## 2.1.2

### 2.1.2.1

66 t/a  
2.5a  
19  
20601.99  
177  
23hm<sup>2</sup>

### 2.1.2.2

12km  
—  
— S240 —  
G55 20km G3511  
23km — —

### 2.1.2.3

66 t/a  
+25m  
12 12

---

					12	12171
12181	2013	1	-2017	3		+230m
	+26.25m		203.75m			1
					4.5m	
						12
				+25m		
203.75m		11m		6.5m		
		+230m		+26.25m		203.75m
3.6m		1		L <sub>7-8</sub>		
12						
		+25m				+6.3m
		GM01-GM04			12	
12		GM05-GM06				
12					12	
						673m
						12

2.1-14

		4.5m	203.75m	6t	
		6.5m 1t	203.75m	11m	
		3.6m	203.75m		
		GM	<sup>1</sup> 12	12 <sub>1</sub>	
		FBCDZNo.20/2×90 1800 5220m <sup>3</sup> /min, 380V 740r/min	YBF	150 2260Pa 90kW	
		20m <sup>3</sup> /min 1	2 SRC-150SA 0.8MPa 108×4mm +25m 12 89×3.5mm	110kW 380V 2	
		2 900kW 2	MD720-60×5 1 6kV	YB3 377×9mm	+25m 5 2 3
			2hm <sup>2</sup>		
			6000m <sup>2</sup> 10000m <sup>3</sup>	5	
			0.25hm <sup>2</sup>	10000t	

		Y008	2.8km	300m	
		35kV LGI-70	4.4km	35kV LGI-120	
			2	250kW	
				500kW	
		860m <sup>3</sup> /h	547m <sup>3</sup> /h	579m <sup>3</sup> /h	
		6.48m <sup>3</sup> /d			
			1 t/a		
			58.3t/a		
		1	3	2	1
				2.5	4
			1		

### 2.1.2.4

1km

1km

1km

200m

---

35kV

35kV

2.1-4

2hm<sup>2</sup>

### 2.1.2.5

1

### 2.1.2.6

1

2020 9 14

C4100002009051120019924 2020 10 31 2022 10

31 30

3.0km 1.8km 5.2787km<sup>2</sup> 1

+140 50m

**2.1-15**

	X	Y		X	Y
1	3895953.10	38365602.55	16	3893563.09	38366677.58
2	3895735.09	38365159.55	17	3894028.10	38366572.58
3	3895717.09	38365172.55	18	3894388.10	38366572.57
4	3895491.09	38364686.54	19	3894478.10	38366887.58
5	3894983.08	38364067.54	20	3894693.10	38366887.57
6	3894133.08	38364552.55	21	3894753.11	38367342.58
7	3893702.07	38365052.56	22	3894673.11	38367487.59
8	3893491.07	38365452.56	23	3895047.11	38367744.59
9	3893853.08	38365452.57	24	3895100.11	38367312.57
10	3893816.09	38365604.57	25	3895604.11	38367197.57
11	3894068.09	38365927.57	26	3895683.11	38367013.56
12	3894138.09	38366202.57	27	3895849.11	38366293.56
13	3893885.09	38366222.58	28	3895945.11	38366092.56
14	3893875.09	38366102.58	29	3896028.10	38365781.55
15	3893465.09	38366137.58	30	3895903.10	38365627.55
	+140 -50m				

2

1

2009 12

1

(111b)+(121b)+(122b)+(333) 2908.8

(111b)1710.8 1198.0

(121b)606.6 (122b)541.9 (333)49.5

2020 12

2020

2020

2020 12 31 3136.94

2325 811.94

255.49 506.95 49.5

2.1-16				t			
				TM	KZ	TD	
1		3136.94	2325	255.49	506.95	49.5	811.94

179.1 t

12011 74723m<sup>2</sup> 1 5m

109755m<sup>2</sup>

59.8 11

1 2m 35

273.9 t

/

/

/

/

=

+

+

×k

k

GB50215-2015

k 0.8

/ 179.1+91.9 273.9 t

/

/

/

/

---

1.

$H_s$

$H_k$

$H_b$

$H_s + H_k + H_b$

$H_k = 6M + 5$

$H_k$

m

$M$

m

1.32m 3.82m

3.82m

$H_k$  27.92m

$H_b = 3A = 11.46m$

$H_s$  39.38m

145m

2.

103m 108m

2.6 t

2.6 t

3. /

$273.9 - 2.6 = 271.3$  t

/

/

1.



=[ / -

]×

1

118m

1 8.0 t

2

3

+25 30m

1 1.0

t

9.0 t

2.

1

16

1 4.25m

78% 78%

2

1 = -

× 1-83 =44.6 t

217.7 t



---

—

10.28m

0.19 5.25m

0.37 8.37m

1 22-5

1.87m 12 12

3 7m 4.25m

1.

1

1.54 1.80 t/m<sup>3</sup> 1.60t/m<sup>3</sup>

1 88.42 94.80%

91.35% 11.68

6.20%

2.

69 2009 2

1 9.94 30.03 14.28

0.44 0.65 0.54 22.88

29.64MJ/kg 27.35MJ/kg

**2.1-18** 1

	Wd	%	68	0.44 5.12	2.56
	Ad	%	68	9.94 30.03	14.28
	Vadf	%	68	2.13 6.96	3.86

	St d	%	42	0.44 0.65	0.54
	Pd	%	13	0.0096 0.07	0.02964
	Qnet d	MJ/kg	35	22.88 29.64	27.35
			36		
			16		1
	Wd	%	9	1.05 1.87	1.57
	Ad	%	9	7.84 14.27	11.76
	Vadf	%	8	1.78 10.94	2.83
	Cadf	%	11	82.57 95.54	92.12
	Hadf	%	11	1.44 3.2	2.00
	Nadf	%	9	0.62 3.27	0.71
	Oadf+Sadf	%	5	1.73 15.10	5.46
	T1		11	1040 1370	1220
	T2		12	1170 1400	1267 1400
	T3		10	1230 1400	1299 1400
	SiO <sub>2</sub>	%	11	43.12 54.11	47.40
	Al <sub>2</sub> O <sub>3</sub>	%	11	27.61 38.72	33.68
	Fe <sub>2</sub> O <sub>3</sub>	%	11	2.99 9.04	5.94
	P <sub>2</sub> O <sub>5</sub>	%	6	0.01 10.629	0.31
	CaO	%	6	0.17 6.21	0.91
	MgO	%	6	1.15 2.57	1.66
	Na <sub>2</sub> O+K <sub>2</sub> O	%	10	0.01 4.15	0.24

3.

1

4.

GB/T5751-2009

V<sub>adf</sub> %

10

1

5.

1

---

1

2.22m<sup>3</sup>/t

### 2.1.2.7

19

### 2.1.2.8

616

583

30

3

1.40

1.30

1.0

### 2.1.2.9

#### 2.1-19

1				
		km	3.0	
		km	1.8	
		km <sup>2</sup>	5.2787	
2				
			1	
		m	4.25	
			4	
		t/m <sup>3</sup>	1.60	
3	/			
		t	273.9	
	/	t	273.9	
	/	t	271.3	
		t	217.7	
4				

	1			
5				
	A <sub>d</sub>	%	9.94 30.03 14.28	
	V <sub>daf</sub>	%	3.40%	
	S <sub>t,d</sub>	%	0.44 0.65 0.54	
	Q <sub>gr,d</sub>	MJ/kg	27.35	
6				
		Mt	0.66	
		t	2000	
7		a	6	
		a	2.5	
8				
		d	330	
			4	
9				
			2	
		m	+25/6.3	
10				
			1	
			2	
			1 MG160/381-WD	
			ZF3600/15/24(A) 126 ZFG3800/17/25 8 ZQL2× 4000/18/35 18	18
			2 SGB630/220	
11				

			2JK-3× 1.5E 1 475kW 1	
			2JK-3× 1.5 1 475kW 1	
			2 2FBCDZNo.20/2× 90	
			5 MD720-60× 5	
			2 SRC-150SA	
12				
13				
		hm <sup>2</sup>	1.67	
		hm <sup>2</sup>	1.67	
		hm <sup>2</sup>		
14				
	( )	m <sup>3</sup>	30735.7	
		m <sup>3</sup>	9331.2	
15				
			616	
			583	
		t/	4.60	
		t/	5.14	
16				
			20601.99	
			9264.33	
			3359.47	
			2472.26	
			2528.23	
			1629.92	
			1347.79	
		/t	312.15	
17				

---

			19	3
			16	

---

## 2.2

### 2.2.1

+25m

+6.3m

12

12

+25m

2.2-1

### 2.2.2

+25

### 2.2.3

### 2.2.4

---

## 2.2.5

547m<sup>3</sup>/h( )  
579m<sup>3</sup>/h( )  
1000 m<sup>3</sup>/h  
8000m<sup>3</sup> 14h  
236.3m( )  
MD720-60×5 5 D  
D

1480r/min YB<sub>3</sub> 900kW 6kV  
377×9mm 3

## 2.2.6

1

EBZ120

8t

8t

2

1

2.2-2

2.2-3

2.2-4

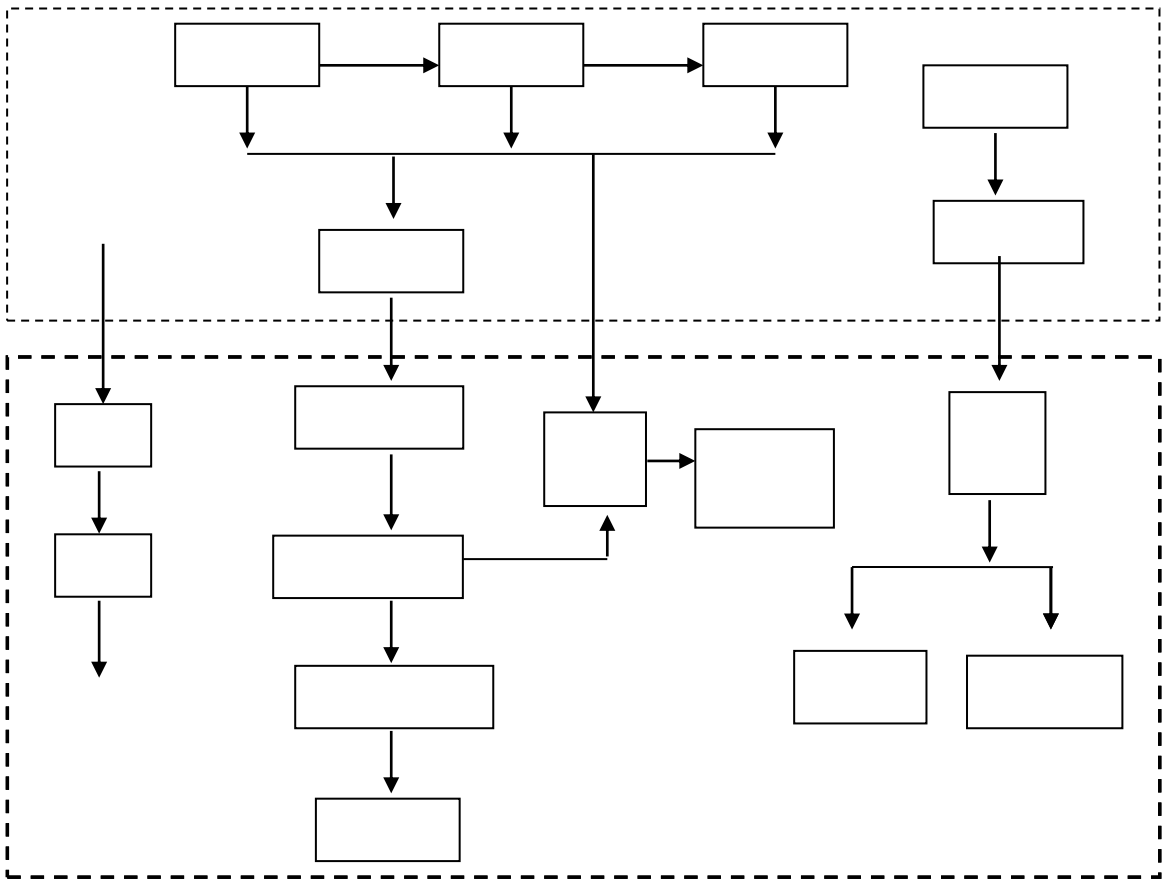

2.2-3

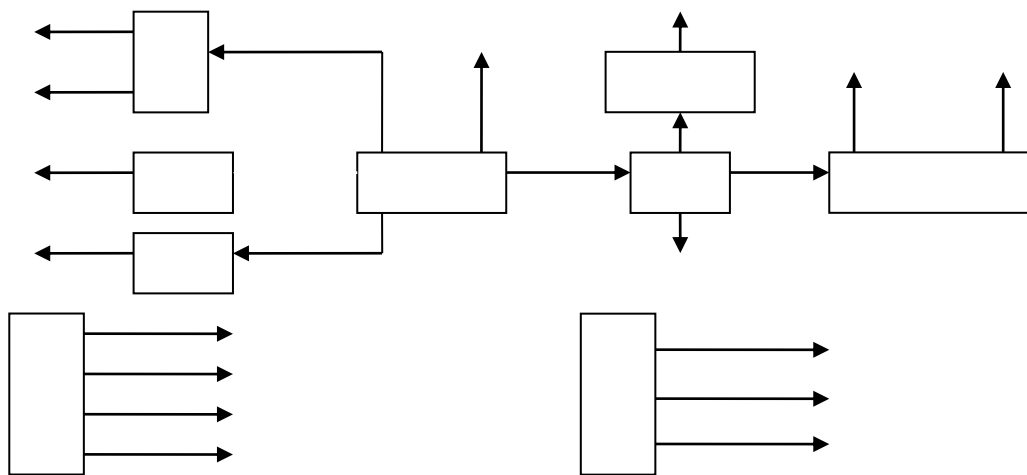

2.2-4

---

## 2.2.7

1

614m<sup>3</sup>/d

(1) 10m<sup>3</sup>/d

(2) 40m<sup>3</sup>/d

(3) 550m<sup>3</sup>/d

(4) 14m<sup>3</sup>/d

2

547m<sup>3</sup>/h

457.13 m<sup>3</sup>/a

6.48m<sup>3</sup>/d

1

860m<sup>3</sup>/h

+

2

6

120-150m

860 m<sup>3</sup>/h

547m<sup>3</sup>/h 13128m<sup>3</sup>/d

550m<sup>3</sup>/d

14m<sup>3</sup>/d

40m<sup>3</sup>/d

12524m<sup>3</sup>/d

2

6.48m<sup>3</sup>/d

COD<sub>Cr</sub> BOD<sub>5</sub> SS

3

11070.84m<sup>3</sup>/d

300m

Y008

2.8km

4

2.2-4

2.2-5

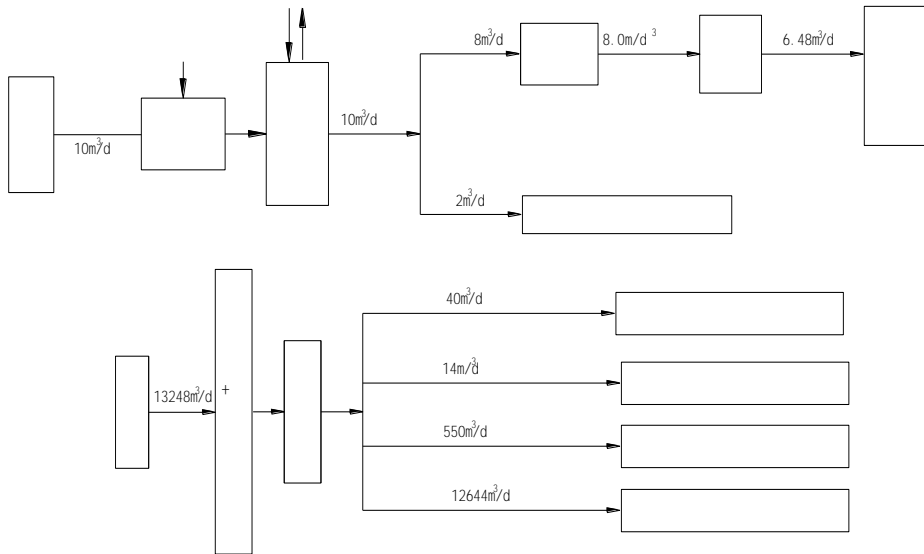

2.2-4

m<sup>3</sup>/d

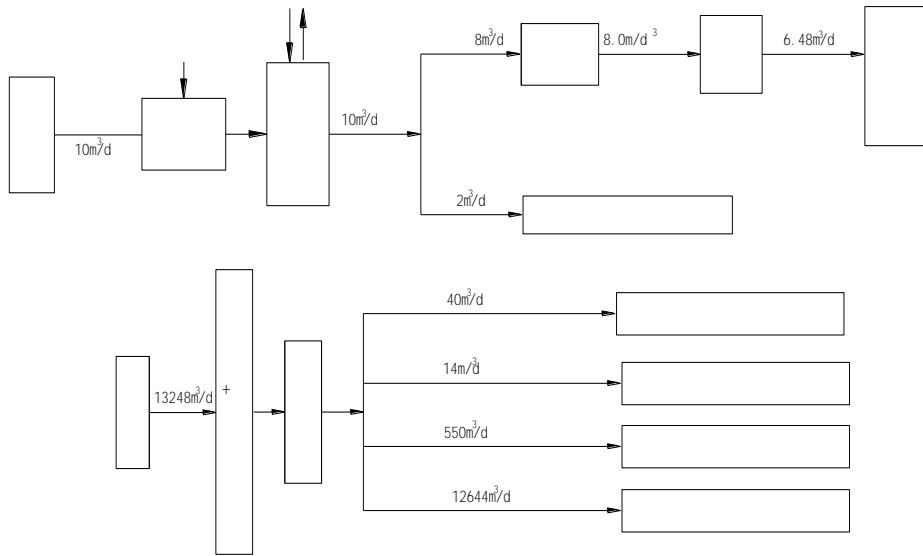

2.2-5

m<sup>3</sup>/d

2.2.8

2.2.9

	35kV		35kV		35kV
		LGJ-120		4.4km	
35kV		LGJ-70		3.4km	
	35kV				
	35kV			35kV	
KYN61-40.5		10		6kV	
	6kV	6kV		35kV	6kV
YJV22-6/10kV		3x95			
		0.35km			

---

	6kV	35kV	6kV
	MYJV42-6/10kV	3× 120	
		MYJV42-6/10kV	3× 95
			2 KBSG-630/6 6/0.69 kV
630kVA			1 KBSG-200/6 6/0.69kV 200kVA

### 2.2.10

800m	Y008	Y008	1.5km
------	------	------	-------

## 2.3

### 2.3.1

1

2

1

" 100%

"

2

3m

" 100% "

3



		"		100%		"
4						
	"	100%	"			
5				"		100%
"						
6						
	"	100%	"			
7					"	1
				100%		"
8						
	"			100%	"	
3						

**2.3-1**

		dB(A)			dB(A)
1		86		3m	73
2		85			72
3		87			74
4		95			82
5		85			72
6		85			72

4

200

0.7kg/( d)

140kg/d

**2.3.2**

**1**

1

547m<sup>3</sup>/h 13128m<sup>3</sup>/d

+

2

6

550m<sup>3</sup>/d

14m<sup>3</sup>/d

40m<sup>3</sup>/d

12524m<sup>3</sup>/d

2013      2023  
 10                      552 m<sup>3</sup>/h  
 547 m<sup>3</sup>/h

2013      2023  
 2.3-2

年份	m <sup>3</sup> /h	年份	m <sup>3</sup> /h	备注
2013	510	2019	550	
2014	545	2020	543	
2015	509	2021	539	
2016	527	2022	740	
2017	547	2023	517	
2018	545			
2013年至2023年平均值			552	

2

6.48m<sup>3</sup>/d                      CODcr   BOD<sub>5</sub>   SS

2.3-1

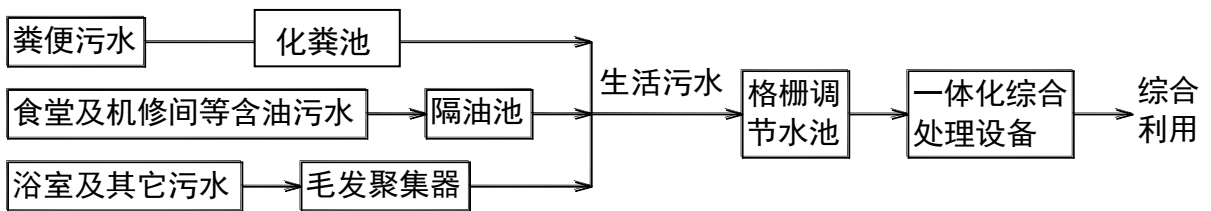

2.3-1

3

12524m<sup>3</sup>/d                      300m      Y008  
 2.8km    13km

IV

---

2

1

15

$$Q = 4.23 \times 10^{-4} U^{4.9} A_p (1 - \eta) \downarrow$$

Q — mg/s

U — m/s

U = 1.7 m/s

A<sub>p</sub> —

—

95%

2023 6

16

2.3-3

	Ap m <sup>2</sup>			t/a
		mg/s	g/h	
	6000	1.71	6.15	0.55

2.3-4

					m <sup>3</sup> /h
		mg/m <sup>3</sup>	mg/s	kg/h	
(DA001)		7.4	21.39	0.077	1.04× 10 <sup>4</sup>
		8.4	23.89	0.086	1.02× 10 <sup>4</sup>
		7.6	21.94	0.079	1.04× 10 <sup>4</sup>
		7.9	22.5	0.081	1.03× 10 <sup>4</sup>
	GB20426-2006	80			
		10			

2

1

3

4

0.03kg/ ·

---

616 18.48kg/d

6.75t/a 2.83%

0.52kg/d 0.17t/a 7h/d

0.075kg/h

2000m<sup>3</sup>/h 12.45mg/m<sup>3</sup>

3 > (2018 4

<

20 mg/m<sup>3</sup>

0.12kg/h 277.2kg/a 95%

60%

0.62mg/m<sup>3</sup> 8mg/m<sup>3</sup>

8.62kg/a

11.09kg/a

DB41/1604-2018 1

3 10mg/m<sup>3</sup>

3

### 2.3-5

		dB(A)	
1		90	
2		75~82	
3		95	
4		95	

1

2

---

3

4

5

6

7

**4**

1

1 t/a

2

58.3t/a

---

3

450t/a

4

3.5t/a

" "

## 2.4

1

2

3

## 2.5

### 2.5-1

			mg/L				
	COD	-	-	4.84× 10 <sup>6</sup> m <sup>3</sup> /a	4.62× 10 <sup>6</sup> m <sup>3</sup> /a		
		416.17	14.67	2014.26t/a	67.78t/a		
		0.756	0.23	3.66t/a	1.06t/a		
	SS	86	15.33	416.24t/a	70.82t/a		
				2356.2m <sup>3</sup> /a	2356.2m <sup>3</sup> /a		
		44.83	18.67	0.11t/a	0.04t/a		
		10.63	4.94	0.03t/a	0.01t/a		
GB5084 2005				20426 2006	1 2		
		-	-	1.8 t/a	0		
		-	-	450t/a	0		
		-	-	3.5t/a	0		
		-	-	58.3t/a	58.3t/a		
		75 96dB A	60 81dB A	-	-		

### 2.5-2

			mg/L				
	COD	-	-	4.79× 10 <sup>6</sup> m <sup>3</sup> /a	4.57× 10 <sup>6</sup> m <sup>3</sup> /a		
		416.17	14.67	1993.45t/a	67.04t/a		
		0.756	0.23	3.62t/a	1.05t/a		

	SS	86	15.33	411.94t/a	70.06t/a	
				2356.2m <sup>3</sup> /a	2356.2m <sup>3</sup> /a	
	COD	44.83	18.67	0.11t/a	0.04t/a	
		10.63	4.94	0.03t/a	0.01t/a	
	20426 2006 1 2					
	GB5084 2005					
		-	-	1.0 t/a	0	
		-	-	450t/a	0	
		-	-	3.5t/a	0	

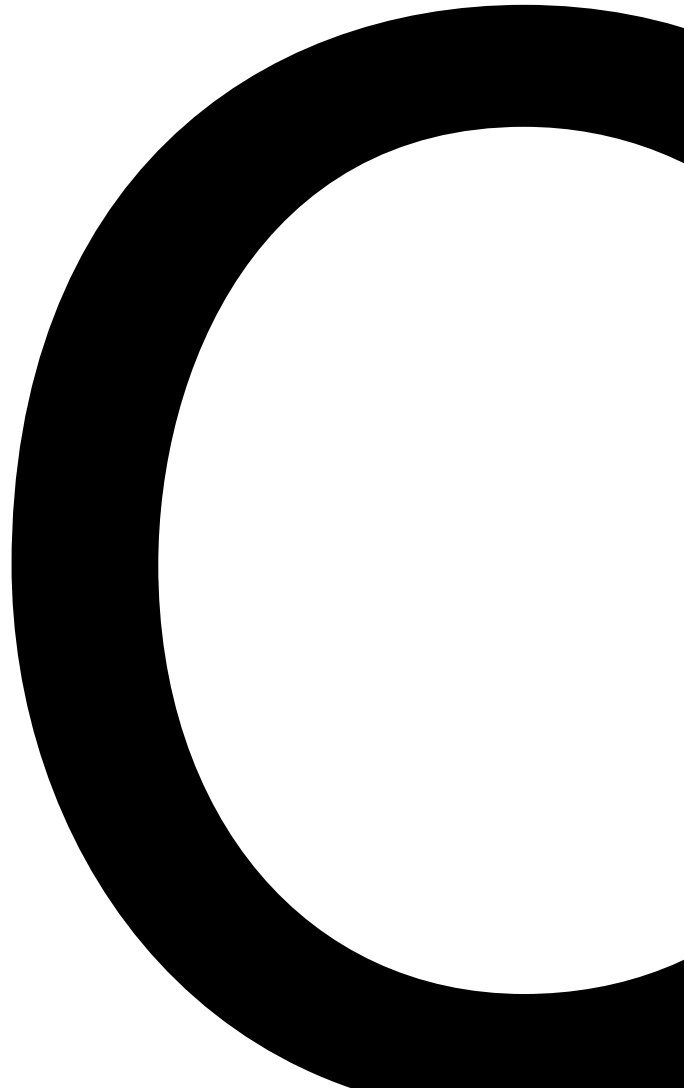
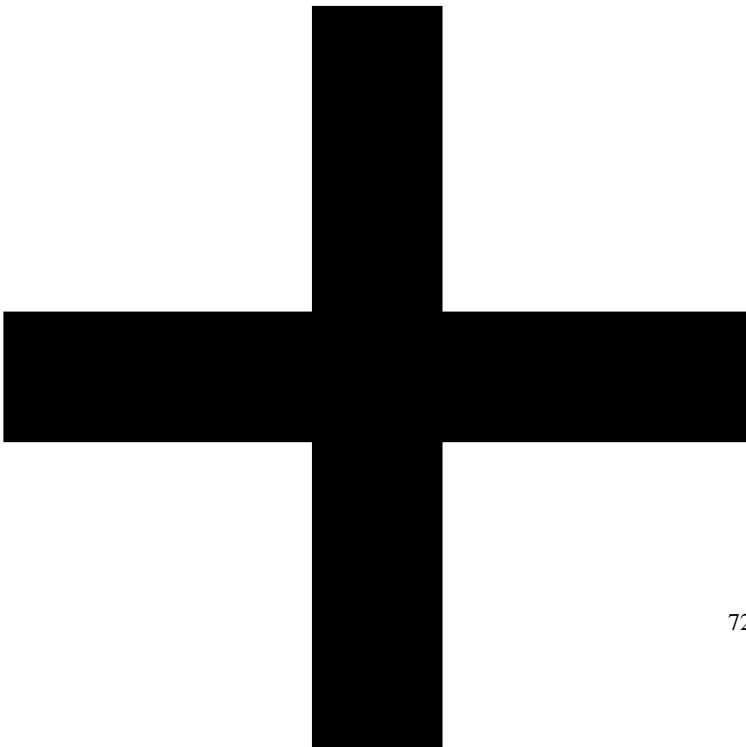

---

## 2.7

### 2.7.1

HJ446-2008

2.7-1

2.7-1

1.						
2.	%			0%	95	
	%			0%	95	
					+U	
3.						
4.	%	100			100	
1.						

2.							
3.							
4.							
5.			<0.10 m <sup>3</sup>		<0.15 m <sup>3</sup>		
1. / kWh/t							69
2. /m <sup>3</sup> /t							0.54
3. m <sup>3</sup> / t /			10	25	30		10
4. / m <sup>3</sup> /t			0.1		0.15		0.15
5. / kW h/t ( )			5	6	8		8

6.	/ kg/t	1	1.5	1.8	1.2	
7.	/ kg/t	1.5	2.0	3.0	2.0	
8.	/%				80%	
9.	/%				93%	
10.	hm <sup>2</sup> / t		0.1	0.12	0.1	
1.	/%				0.46	
	/%				12.88	
1.	g/t				54.383	
2.	g/t				0.008	
3.	t/t				0.05	
4.			mg/m <sup>3</sup>		/	/
1.	%					/
2.	%				100	
3.	%				100	
1.	%				90	
2.	%	100			/	/
3.	%				15	
1.						
2.		GB/T 24001	GB/T 24001			
3.						

	100%	98%	95%		
4.	GB20426 GB18599				
4.					
5.					



---

## 3.1

### 3.1.1

280m

213m

67m

### 3.1.2

14.3 °C

42°C

-18.5 °C

ESE 10.0%

SW 8.7%

1.7m/s

578.3mm

1810.2mm

0.30.4

70%

2363.7h

54%

1001.3hPa

223

---

### 3.1.3

#### 3.1.3.1

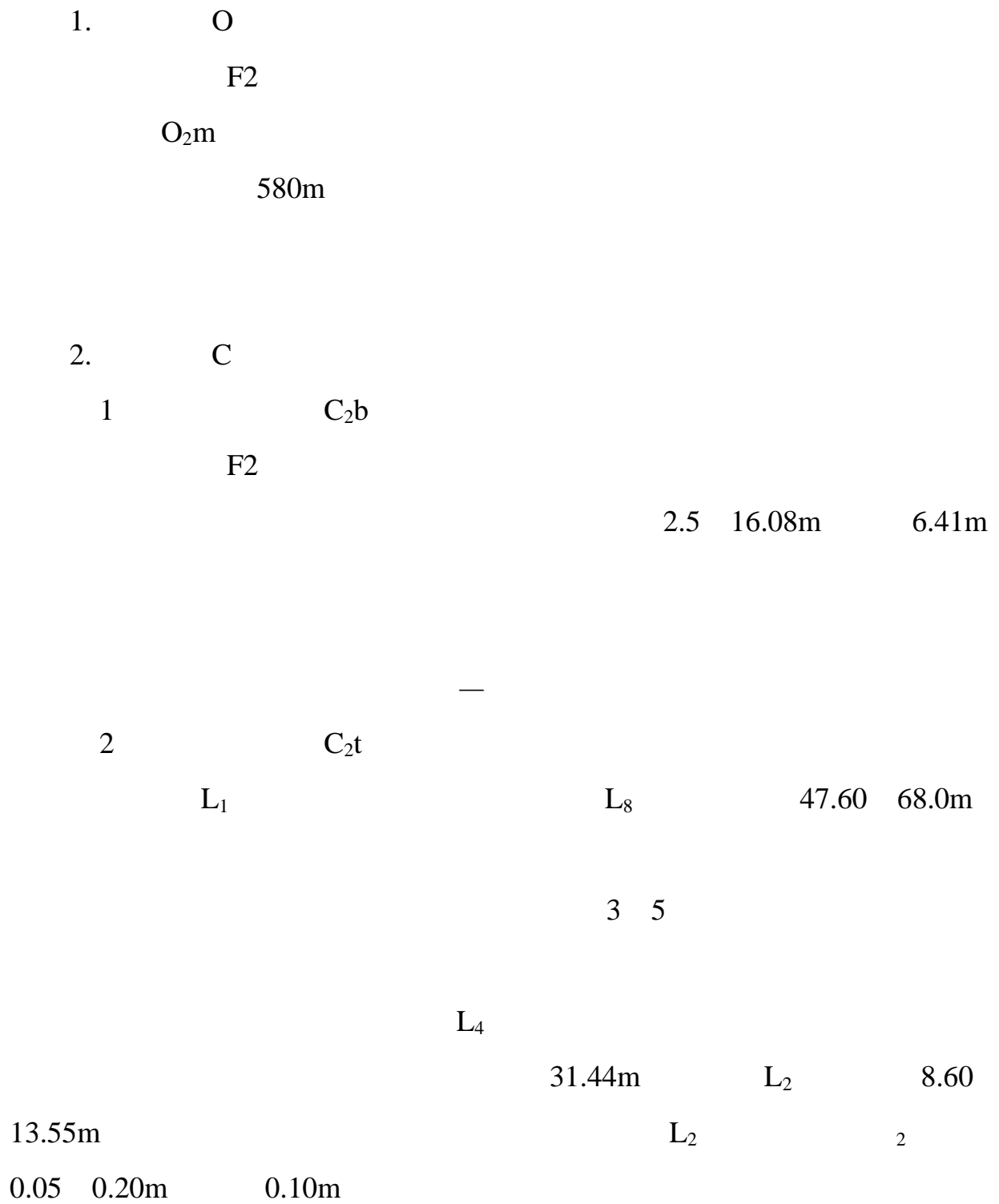

---

L<sub>4</sub> L<sub>7</sub> 10.33 49.33m 22.68m  
 1 2  
 L<sub>5</sub> L<sub>7</sub> L<sub>5</sub> 5  
 0.25 1.81m 0.58m  
 L<sub>7</sub> 6.20 16.24m  
 9.79m  
 L<sub>8</sub> 1.98 5.64m  
 3.83m  
 3. P  
 1 P<sub>1s</sub>  
 87.50m 1 40  
 1 20.0m  
 1  
 0.00 13.91m 3 7m  
 1  
 0.24 29.81m  
 45m 1 2 -  
 1  
 2 P<sub>1x</sub>

---

209.17m

(4)        N                    Q

4.8 55.40m

### 3.1.3.2

1.

1

22-4 CK3        2        3

7

9°

4°

2

13-1 CK26 CK11

9° 15°

8° 14°

3

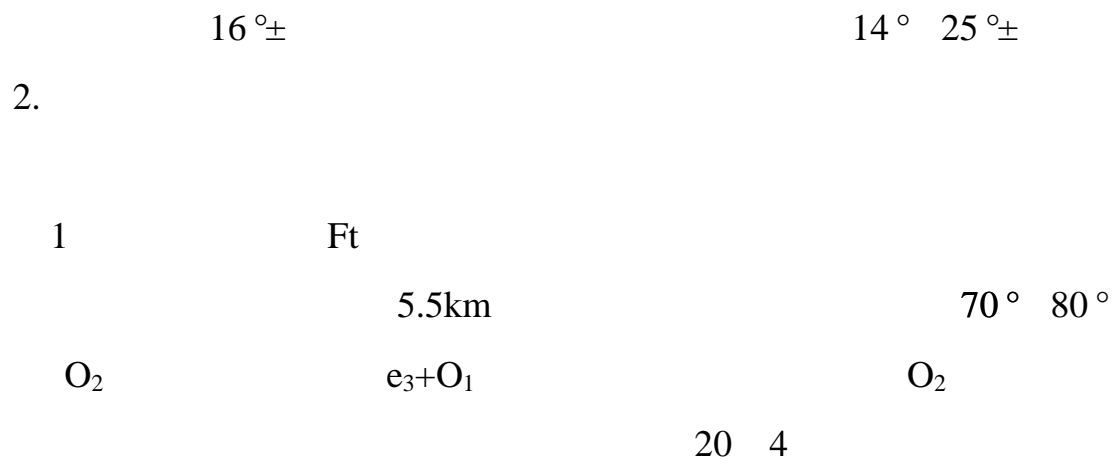

---

46 613  
166 1.11  
3.5m<sup>3</sup>/s  
35km 1/20 1/60 240  
3.5km  
0.2m<sup>3</sup>/s 18.5km 92km<sup>2</sup>  
485.1 13532 41  
140 15.6  
m<sup>3</sup> 44.4m<sup>3</sup>/s  
30  
58

---

1/50	70km <sup>2</sup>	158mm	18km	0.11	1/15	m <sup>3</sup>
------	-------------------	-------	------	------	------	----------------

3.1-1

15	/					10
----	---	--	--	--	--	----

5 10 /

5 0 /

3.0	10 45					0.8
-----	-------	--	--	--	--	-----

2 / 50 75 /

3.1.5

7



---

66 t/a

2024

3.2.2

2016 7

1

2016 2 1

2016 7

4 22

2016 3 5

5

5

2016 3

13

30 /

15 /

---

1 3

1

---

---

---

4

60 /

11

30 /

9 /

2014

---

2

3

"

"

"

"



3

300 /

2

66 t/a 2007 3 20  
2006

2007 193

66 t/a

13

2016 7

3.2.3

2016 27

1

( )

---

( )

" " ( )

( ) "

"

"

"

( )

;

2

3.2.4

3.2-1

	" "		15m
	" "		
	100%	100%	
	100%		

	" "		
	100%		
	85%	3.2km	
	" "		
	1%	1%	

---

3.2.5

**3.2-2**

	2011		

3.2.6

[2016]114

**3.2-3**

[2016]114

	HJ446	HJ446	

	3		
	GB18599-2020		
	GB12348	GB12348	
	" "	" "	

		2019	
	1 / 1Bq/g	/ 1Bq/g	1

3.2.7

( )

2015 107

2015 107

3.2-4

	2015 107	
1		
2		
3		1

3.2.8

1

---

**2010**

1 90%

75%

2 65%

3

85%

4 55% 10%

5 20%

75%

**2015**

1 2010

3%

2

2010

5%

3

45%

85%

**2**

100%

100%

2005 109

" 2015

70%

60% "



**3.2-6**

**2024**

2024			
24.			
25.	" "		

**3.2-7**

**2024**

2024			
2.	" " 6 20% 2024 6	GB18597-2023)	
9.	" "		

3.2.10

2024

[2024]19

3.2-8

2024

<p>6.</p>	<p>“ ” ， ， 150 ， “ ”</p>		
<p>7.</p>	<p>“ ” + “ ” 2024 ， 80% ( ) 20% 10% ( ) ，</p>	<p>80%</p>	
<p>20.</p>	<p>“ ” “ ” “ ” “ ” 5000 80%</p>		

3.2.11

2024

[2024]20

**3.2-9**

**2024**

17.		2024	
18.	"	"	

3.2.12

2024

[2024]21

**3.2-10**

**2024**

2.	" 6 20% 7 11	" GB18597-2023)	
9.	" "	3	

---

3.2.13

**1**

---

2

1 2010

(2010)199

2

3

1

4

3.2.14

3.2.14.1

2021 12 31

[2021]44

2025

V



V

2035

---

2025

5%

3.2.14.2

1

2025

GDP

PM<sub>2.5</sub> O<sub>3</sub>

100%



2035

3.2-11

表3.2-11

规划目标一览表

			2020	2025	
1		g/m <sup>3</sup>	54	44	
2		%	62.7	64.5	
3		g/m <sup>3</sup>	/		
4		%	60	77.8	
5		%			
6		%	100	100	
7		%			
8		%	0		
9		%	46.8	60	
10		%	14		
11		%	-		
12		%	[22.7]		
13		%	-	10	
14			-		
15		%	10		
16		%	-		
17		t	-	[1731]	
18		t	-	[403]	
19		t	-	[2705]	
20		t	-	[101]	
21		%	-		
22		%		95	
23					
24		/		0	
25		%		100	
26		%		100	
27		%		45.58	

	28	EQI					
	29						
1. [] 2. 4 5 2020 5 2025 9 3.							

80%

I

3.2.15

2025 PM<sub>2.5</sub>  
46 66.5% PM<sub>10</sub>  
81 1.5% 5  
PM<sub>2.5</sub>

95%

80%

10

3.2.16 与《煤炭工业 十四五 高质量发展指导意见》（中煤协会政研（2021）9号）相符性分析

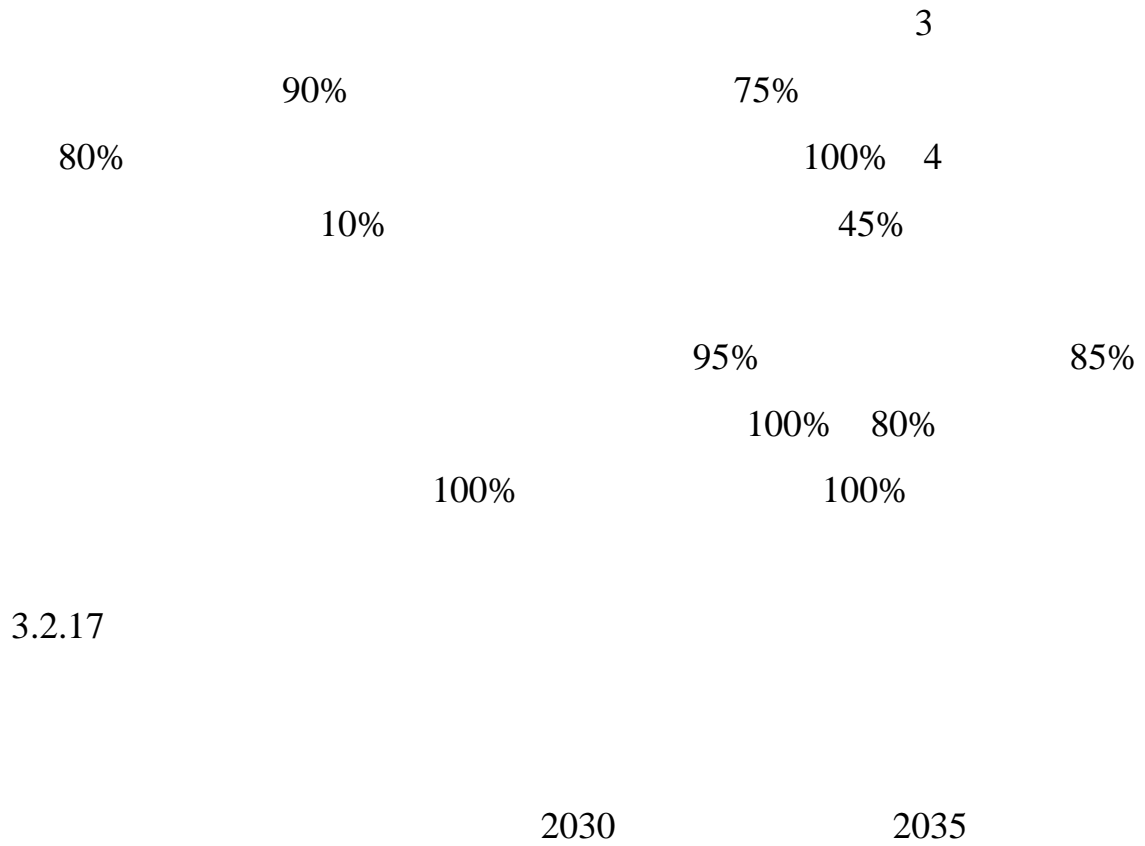

3.2.17

3.2-12

<p>.....</p> <p>.....</p>	<p>GB18597-2023)</p>	
<p>.....</p> <p>.....</p> <p>2021</p>		

3.2.18

"

3.2.18.1

"

"

2020 37

1

"

"

2020 37

ZH41900110003

ZH41900130001

3.2-10

2

"

"

"

3.2-1

ZH41900110003

ZH41900130001

3.2.18.2

"

"

"

"

3. 2-13

"

"

		1.	1	
		2.		
		3.		
		4.		
		5.		

		6. 7. 8.	2 3 4 6 7 8	
		1. VOCs 2. 3. 4. 5. 6.		
		1. 2. 3. 4. 5. 6.	2. 3. 4. 5.	
		1. 2. 3. 4.		

		1.	—	—		2.		
			—	—				

3.2.19

3.2.19.1

2019 125

2021 206

1

245

2

830

275

3000

4000

3.2.19.2

14

3.2-2

3.2.20

3.2.20.1

2016

23

1

4

670

670

480

2

577

200

2000

3

753

200

2000

3.2.20.2

### 3.3

2.5km

5.5km

3.3-1



3.3-1

### 3.4

- 1 GB3095-2012
- 2 GB3838-2002 IV
- 3 GB/T14848-2017
- 4 GB3096-2008 2
- 5 GB5084-2005
- 6 GB15618-2018  
GB36600-2018

### 3.5

- 3.5.1
- 3.5.1.1

GB3095-2012  
2023

2023

3.5-1 2023

3

				%	
PM <sub>10</sub>	2023	81	70	115.7	
PM <sub>2.5</sub>	2023	49	35	140.0	
SO <sub>2</sub>	2023	10	60	16.7	
NO <sub>2</sub>	2023	29	40	72.50	
CO	2023 24 95	1800	4000	45	
	22023 8h 90	180	160	112.5	

2023

SO<sub>2</sub>

NO<sub>2</sub> CO<sub>24</sub>

95

GB3095-2012

PM<sub>10</sub> PM<sub>2.5</sub>

8h

90

GB3095-2012

2019~2023

5

3.5-2

COmg/m<sup>3</sup>

3

	PM10	PM2.5	SO2	NO2	CO	O3
2019	97	64	17	35	2.2	196
2020	90	54	13	34	1.1	172
2021	79	47	11	30	1.7	183
2022	85	53	11	29	1.8	178
2023	81	49	10	29	1.8	180
	70	35	60	40	4	160

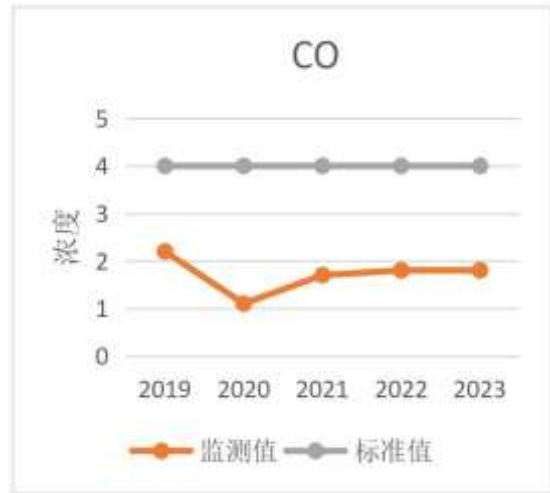
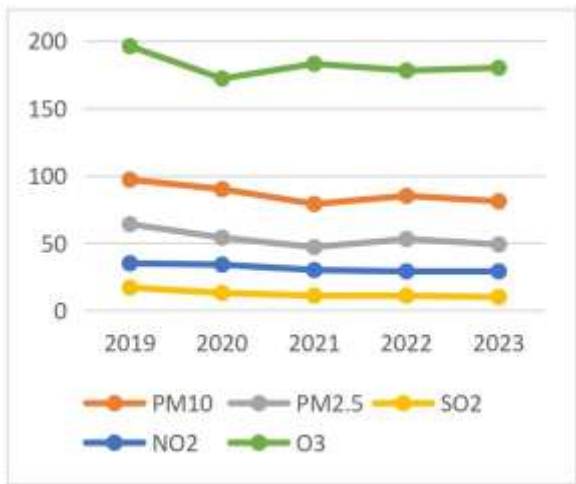

2019~2023

$\mu\text{g}/\text{m}^3$   $\text{COmg}/\text{m}^3$

2019~2023

PM<sub>2.5</sub> PM<sub>10</sub> O<sub>3</sub>  
PM<sub>10</sub> PM<sub>2.5</sub> SO<sub>2</sub> NO<sub>2</sub>

90

CO

O3

2023

2024

2024 7

2023 13

3.5.1.2

1

2

3.5-1

表 3.5-1

环境现状监测布点情况表

布点编号	监测项目	监测距离	备注
1#	/	/	
2#	50m	410m	

2

TSP PM10 PM2.5

SO2 NO2

GB3095-2012

3.5-2

TSP	GB/T 15432-1995	BS-E120B DSYQ-N006-2	0.001mg/m <sup>3</sup>
PM <sub>10</sub>	PM <sub>10</sub> PM <sub>2.5</sub> HJ 618-2011	BS-E120B DSYQ-N006-2	0.010mg/m <sup>3</sup>
PM <sub>2.5</sub>	PM <sub>10</sub> PM <sub>2.5</sub> HJ 618-2011	BS-E120B DSYQ-N006-2	0.010mg/m <sup>3</sup>
	- HJ 482-2009	TU-1810 DSYQ-N004-5	0.007mg/m <sup>3</sup> 0.004mg/m <sup>3</sup>
	HJ 479-2009	TU-1810 DSYQ-N004-5	0.005mg/m <sup>3</sup> 0.003mg/m <sup>3</sup>

3

2023

11 7 13

7

3.5-3

TSP	24	7	24h
PM <sub>10</sub> PM <sub>2.5</sub>	24	7	20h
SO <sub>2</sub> NO <sub>2</sub>	24	7	20
	1	02 08 14 20 45	4

4

GB3095-2012

5

Pi=Ci/Si

Pi i

Ci i mg/Nm<sup>3</sup>

Si i mg/Nm<sup>3</sup>

6

TSP PM<sub>10</sub> PM<sub>2.5</sub> SO<sub>2</sub> NO<sub>2</sub>24h

SO<sub>2</sub> NO<sub>2</sub>

3.5-4

		μg/m <sup>3</sup>	μg/m <sup>3</sup>		%	
TSP 24		185 235	300	0.62 0.78	0	0
		183 237		0.61 0.79	0	0
PM <sub>10</sub> 24		81 118	150	0.54 0.79	0	0
		85 118		0.57~0.79	0	0
PM <sub>2.5</sub> 24		32 46	75	0.43 0.61	0	0
		32 48		0.43 0.64	0	0
SO <sub>2</sub> 24		11 18	150	0.07 0.12	0	0
		11 16		0.07 0.11	0	0
SO <sub>2</sub> 1		9 26	500	0.02 0.05	0	0
		10 24		0.02 0.05	0	0
NO <sub>2</sub> 24		18 28	80	0.23 0.35	0	0
		22 31		0.28 0.39	0	0
NO <sub>2</sub> 1		17 31	200	0.09 0.16	0	0
		21 33		0.11 0.17	0	0

GB3095-2012

## 3.5.2

### 3.5.2.1

2023

2023

3.5-5

		COD				
2023	1	15	0.74	0.203		
2023	2	16.5	0.73	0.204		
2023	3	18.5	0.77	0.175		
2023	4	16	0.91	0.209		
2023	5	21	1.0	0.286		
2023	6	23.5	0.38	0.173		
2023	7	22.5	0.62	0.228		
2023	8	24.5	0.49	0.202		
2023	9	22	0.6	0.231		
2023	10	16.5	0.28	0.17		
2023	11	17.5	0.78	0.155		
2023	12	17.5	0.78	0.155		
		19.250	0.673	0.199		
	GB3838 2002	30	1.5	0.3		
	GB3838 2002 III	20	1.0	0.2		
	%	0	0	0		

--	--	--	--	--	--

COD

GB3838-2002 III 2023

COD

COD 41.7% 0.225 58.3%  
0.43 GB3838-2002

III

5.3.2.2

1

300m

2.8km

3km

10km

3.5-6

1		200
2		500
3		500

2

pH

COD BOD<sub>5</sub>

20

3

2023 11 7 9

3

4

## GB3838-2002

5

## 3.5-7

	( ) ( )		/
pH	pH HJ 1147-2020	pH PHBJ-260F HYKD2022066	/
	GB 13195-91	0-40 HYKD2022135	/
	11901-89 GB	PX224ZH/E HYKD2022092	/
	HJ 828-2017	50.00mL	4mg/L
	BOD <sub>5</sub> HJ 505-2009	SHP-250 HYKD2022083	0.5mg/L
	GB 7484-87	PXSJ-216F HYKD2022060	0.05mg/L
	HJ 535-2009	T6 HYKD2022015	0.025mg/L
	GB 11893-89		0.01mg/L
	HJ 970-2018	TU-1901 HYKD2022016	0.01mg/L
	HJ 694-2014	AFS-933 HYKD2022014	0.04μ g/L
			0.3μ g/L
	GB 7467-87	T6 HYKD2022015	0.004mg/L
	65 HJ 700-2014	7850 HYKD2022010	0.82μ g/L
			0.12μ g/L
			0.67μ g/L
			0.09μ g/L
			0.11μ g/L

	( ) ( )		/
			0.05μ g/L
	HJ 1226-2021	T6 HYKD2022015	0.01mg/L
	4- 1 HJ 503-2009		0.0003mg/L
	51-1999 HJ/T	PX224ZH/E HYKD2022092	/

6

$$S_{ij} = C_{ij} / C_{si}$$

$$S_{ij} = \frac{C_{ij}}{C_{si}}$$

i j

C<sub>ij</sub> i j mg/L

C<sub>si</sub> i mg/L

pH

$$S_{pH_j} = (7.0 - pH_j) / (7.0 - pH_{sd}) \quad pH_j \quad 7.0$$

$$S_{pH_j} = (pH_j - 7.0) / (pH_{su} - 7.0) \quad pH_j \quad 7.0$$

$$S_{pH_j} = \frac{pH_j - pH_{sd}}{pH_{su} - pH_{sd}}$$

pH j

pH<sub>sd</sub> j pH

pH<sub>su</sub> pH

7

3.5-8

(pH ) mg/L

		200 W1	500 W2	500 W3	GB3838-2002IV	
1	pH	8.3 8.4	8.0 8.2	8.3 8.5	6~9	
2		21 28	14 16	12 19	/	
3		16	12 13	14	30	
4		3.4 3.5	3.3 3.4	3.3 3.4	6	
5		0.198 0.214	0.108 0.121	0.114 0.126	1.5	
6		0.71 0.76	0.42 0.43	0.50 0.52	1.5	
7		0.04 0.08	0.05 0.06	0.06 0.09	0.3	
8		0.01L	0.01L	0.01L	0.5	
9		0.0003L	0.0003L	0.0003L	0.01	
10		0.04	0.03	0.03	0.5	
11		0.01 0.011	0.006 0.011	0.0136 0.0171	0.3	
12		0.01 0.011	0.009 0.013	0.0026 0.0031	0.1	
13		0.00004L	0.00004L	0.00004L	0.001	
14		0.0016 0.0018	0.0019 0.0028	0.0025 0.0028	0.005	
15		0.00013 0.00017	0.00024 0.00048	0.0004 0.0006	0.05	
16		0.017 0.019	0.033 0.049	0.017 0.022	2.0	
17		0.00034 0.00042	0.00025 0.00045	0.01 0.011	/	/
18		0.004L	0.004L	0.004L	0.05	
19		0.0164 0.0166	0.00554 0.0056	0.00117 0.00012	0.1	
20		920 958	626 651	790 812	1000	

1 " L"

8

GB3838-2002 IV

### 3.5.3

1

3.5-1

3.5-9

1#	1		
2#	1		
3#	1		
4#	1		
5#	1		
6#	1		
7#	1		
8#	2		
9#	2		
10#	1		
11#	2		
12#	2		
13#	2		
14#	2		

2

pH

$K^+$   $Na^+$   $Ca^{2+}$

$Mg^{2+}$   $CO_3^{2-}$   $HCO_3^-$   $Cl^-$   $SO_4^{2-}$

3

8  
4

2

## 3.5-10

pH	pH 1147-2020	HJ	pH PHBJ-260F HYKD2023043	/
				0.05mg/L
		GB 11904-89		0.01mg/L
			ICE3500 HYKD2022012	0.02mg/L
		GB 11905-89		0.002mg/L
CO <sub>3</sub> <sup>2-</sup>				/
HCO <sub>3</sub> <sup>-</sup>	2002		50.00mL	/
		GB 7484-87	PXSJ-216F HYKD2022060	0.05mg/L
Cl <sup>-</sup>				0.007mg/L
SO <sub>4</sub> <sup>2-</sup>				0.018mg/L
N	NO <sub>3</sub> <sup>-</sup> PO <sub>4</sub> <sup>3-</sup> SO <sub>3</sub> <sup>2-</sup> SO <sub>4</sub> <sup>2-</sup>	F <sup>-</sup> Cl <sup>-</sup> NO <sub>2</sub> <sup>-</sup> Br <sup>-</sup> HJ 84-2016	ICS-600 HYKD2022013	0.004mg/L
				0.018mg/L
				0.007mg/L
		HJ 535-2009		0.025mg/L
		GB 7493-87		0.003mg/L
	4- 1 HJ 503-2009		T6 HYKD2022015	0.0003mg/L
	7.1	5 -		0.002mg/L
		GB/T 5750.5-2023		

	6 13.1 GB/T 5750.6-2023		0.004mg/L
CaCO <sub>3</sub>	EDTA GB 7477-87	25.00mL	0.05mmol/L
	4 11.1 GB/T 5750.4-2023	PX224ZH/E HYKD2022092	/
	GB 11892-89	25.00mL	0.05mg/L
	65 HJ 700-2014	7850 HYKD2022010	0.12 /L
	HJ 694-2014	AFS-933 HYKD2022014	0.3
	2002 HJ 1000-2018	SHP-250 HYKD2022084	/
			/

5

1

GB/T14848-2017

2

GB/T14848-2017

3

GB/T14848-2017

## 3.5-11

		m	m	m
1	1	200	200	60
2	1	160	143	60
3	1	200	170	60

3.5-12

pH mg/L

									(mg/L)	
	11.7	11.8	11.7	11.8	11.7	11.8	11.7	11.8		
pH	7.4	7.4	7.4	7.4	7.4	7.4	7.5	7.4	6.9	
K <sup>+</sup> mg/L	0.93	0.90	0.92	0.91	0.66	0.63	0.76	0.75	/	
Na <sup>+</sup> mg/L	11.8	12.5	11.0	11.3	6.98	6.27	6.86	6.78	/	
Ca <sup>2+</sup> mg/L	107	89.2	100	85.2	70.5	56.8	80.1	65.6	/	
Mg <sup>2+</sup> mg/L	37.0	37.0	35.8	35.9	24.4	24.7	31.2	31.3	/	
CO <sub>3</sub> <sup>2-</sup> mg/L	0	0	0	0	0	0	0	0	/	
HCO <sub>3</sub> <sup>-</sup> mg/L	342	342	300	302	263	256	270	252	/	
Cl <sup>-</sup> mg/L	13.8	13.8	24.6	24.7	11.8	11.8	13.8	13.8	/	
SO <sub>4</sub> <sup>2-</sup> mg/L	83.2	82.1	103	105	52.4	50.9	81.8	85.4	/	
mg/L	0.20	0.20	0.23	0.23	0.15	0.15	0.16	0.16	1.0	
mg/L	13.8	13.8	24.6	24.7	11.8	11.8	13.8	13.8	250	
mg/L	83.2	82.1	103	105	52.4	50.9	81.8	85.4	250	
N mg/L	9.84	10.6	11.3	10.8	9.61	9.56	9.32	10.8	20	
mg/L	0.207	0.170	0.041	0.065	0.025L	0.025L	0.158	0.120	0.5	
mg/L	0.003L	0.003L	0.003L	0.003L	0.003L	0.003L	0.003L	0.003L	1.0	
mg/L	0.0003L	0.0003L	0.0003L	0.0003L	0.0003L	0.0003L	0.0003L	0.0003L	0.002	
mg/L	0.002L	0.002L	0.002L	0.002L	0.002L	0.002L	0.002L	0.002L	0.05	
mg/L	0.004L	0.004L	0.004L	0.004L	0.004L	0.004L	0.004L	0.004L	0.05	
CaCO <sub>3</sub> mg/L	416	391	362	372	252	257	316	303	450	

mg/L	458	470	457	466	317	308	396	380	1000	
mg/L	1.58	1.67	1.62	1.73	1.69	1.57	1.76	1.68	3.0	
μ g/L	0.09L	0.09L	0.09L	0.09L	0.09L	0.09L	0.09L	0.09L	0.01	
μ g/L	0.05L	0.05L	0.10	0.10	0.05L	0.05L	2.50	2.36	0.005	
μ g/L	4.04	5.02	0.99	0.96	0.82L	0.82L	0.82L	0.82L	0.3	
μ g/L	0.3L	0.3L	0.3L	0.3L	0.3L	0.3L	0.4	0.3	0.01	
μ g/L	0.92	0.96	0.39	0.30	0.13	0.14	1.16	1.06	0.1	
μ g/L	0.04L	0.04L	0.04L	0.04L	0.04L	0.04L	0.04L	0.04L	0.001	
MPN/100mL	<2	<2	<2	<2	<2	<2	<2	<2	3.0	
CFU/mL	48	51	50	49	50	46	50	43	/	

3.5-12

pH mg/L

	11.7		11.8		11.7		11.8			
pH	7.5	7.5	7.6	7.4	7.4	7.5	6	9		
K <sup>+</sup> mg/L	0.80	0.79	0.85	0.84	0.65	0.64	/			
Na <sup>+</sup> mg/L	8.46	7.92	7.12	7.94	6.60	6.66	/			
Ca <sup>2+</sup> mg/L	67.3	54.4	57.4	42.2	75.3	59.0	/			
Mg <sup>2+</sup> mg/L	33.4	33.8	26.4	26.1	29.4	29.1	/			
CO <sub>3</sub> <sup>2-</sup> mg/L	0	0	0	0	0	0	/			
HCO <sub>3</sub> <sup>-</sup> mg/L	260	250	160	143	251	243	/			
Cl <sup>-</sup> mg/L	13.9	13.8	18.8	18.8	14.0	14.0	/			
SO <sub>4</sub> <sup>2-</sup> mg/L	80.3	79.9	95.4	96.2	67.1	66.4	/			

mg/L	0.14	0.13	0.16	0.17	0.29	0.28	1.0	
mg/L	13.9	13.8	18.8	18.8	14.0	14.0	250	
mg/L	80.3	79.9	95.4	96.2	67.1	66.4	250	
N mg/L	10.5	10.0	9.00	9.05	10.3	10.8	20	
mg/L	0.025L	0.025L	0.094	0.123	0.068	0.105	0.5	
mg/L	0.003L	0.003L	0.003L	0.003L	0.003L	0.003L	1.0	
mg/L	0.0003L	0.0003L	0.0003L	0.0003L	0.0003L	0.0003L	0.002	
mg/L	0.002L	0.002L	0.002L	0.002L	0.002L	0.002L	0.05	
mg/L	0.004L	0.004L	0.004L	0.004L	0.004L	0.004L	0.05	
CaCO <sub>3</sub> mg/L	291	283	231	217	281	284	450	
mg/L	396	355	332	302	379	354	1000	
mg/L	1.51	1.73	1.76	1.59	1.64	1.81	3.0	
μ g/L	0.09L	0.09L	0.45	0.47	0.09L	0.09L	0.01	
μ g/L	0.05L	0.05L	0.06	0.05	0.05L	0.05L	0.005	
μ g/L	4.72	4.67	7.53	7.34	4.61	5.12	0.3	
μ g/L	0.4	0.4	0.3L	0.3L	0.4	0.4	0.01	
μ g/L	2.79	2.51	2.08	1.98	1.70	1.77	0.1	
μ g/L	0.04L	0.04L	0.04L	0.04L	0.04L	0.04L	0.001	
MPN/100mL	<2	<2	<2	<2	<2	<2	3.0	
CFU/mL	57	53	63	62	52	53	/	

### 3.5.4

1

1

3.5-1

5

4

1

3.5-13

	50m	

2

3

2023 6 16

2023 11 11 -12

4

GB3096-2008

A

2

3

GB3096-2008

2

60dB A

50dB A

4

3.5-14

dB A

3.5-14

		L <sub>Aeq</sub> [dB(A)]					GB3096-2008 2
2023.6.16		53	54	52	52		60
		44	43	41	42		50
2023.11.11		53	50	44	42	44	60
		47		39	40	40	50
2023.11.12		51	56	47	42	46	60
		42	44	38	37	37	50

GB3096-2008 2

3.5.5

1

HJ964-2018

9

6

3

2

4

5#

2#-4#

7# 8#

9#

2

2023 11 9 -10

3

CB15618-2018 1



3.5-15

	1#			pH+8	0~0.2m ( )
	6#				GB15618-2018
	2#			pH + +45	0~0.2m 0~0.5m 0.5~1.5m 1.5~3m GB36600-2018 HJ25.1
	3#			pH+45	
	4#			pH+45	
	5#				
	7#			pH 8	HJ964-2018 ( ) GB15618-2018
	8#				
	9#				
	6#			pH	HJ964-2018
	9#				

3.5-16

			0-0.5m	0.5-1.5m	1.5-3.0m	0-0.5m	0.5-1.5m	1.5-3.0m	0-0.5m	0.5-1.5m	1.5-3.0m		
2023 11 9	pH	/	8.02	8.00	8.01	7.77	7.80	7.74	7.70	7.68	7.72	8.15	5.5-8.5
		mg/kg	16.0	15.3	11.6	28.4	12.3	13.8	28.4	12.4	13.6	14.9	60
		mg/kg	20.1	32.4	22.8	138	20.0	44.5	73.0	44.7	29.1	28.6	800
		mg/kg	0.17	0.05	0.15	0.32	0.14	0.09	0.27	0.17	0.18	0.17	65
		mg/kg											5.7
		mg/kg	0.102	0.135	0.016	0.160	0.026	0.052	0.203	0.024	0.024	0.169	38
		mg/kg	8	24	19	93	20	21	102	21	21	28	18000
		mg/kg	23	32	28	23	29	27	24	33	32	27	900
		mg/kg											2.8
		mg/kg											0.9
		mg/kg											37
		1,1-	mg/kg										9
		1,2-	mg/kg										5
		1,1-	mg/kg										66
		-1,2-	mg/kg										596
	-1,2-	mg/kg										54	
		mg/kg										616	

1,2-	mg/kg												5
1,1,1,2-	mg/kg												10
1,1,2,2-	mg/kg												6.8
	mg/kg	19.3				7.8			20				53
1,1,1-	mg/kg												940
1,1,2-	mg/kg												2.8
	mg/kg												2.8
1,2,3-	mg/kg												0.5
	mg/kg												0.43
	mg/kg												4
	mg/kg												270
1,2-	mg/kg												560
1,4-	mg/kg												20
	mg/kg												28
	mg/kg												1290
	mg/kg												1290
, -	mg/kg												570
	mg/kg												640
	mg/kg												260
	mg/kg												76
2-	mg/kg												2256
[a]	mg/kg												15

	[a]	mg/kg											1.5
	[b]	mg/kg											15
	[k]	mg/kg											151
		mg/kg											1293
	[a, h]	mg/kg											1.5
	[1,2,3-cd]	mg/kg											15
		mg/kg											70
		mg/kg	10	15	10	/	/	/	-	-	-	-	5000
pH			HJ964-2018 D										
			GB36600-2018										

3.5-17

2023.11.10	pH	/	7.94	7.88	5.5-8.5
		mg/kg	0.092	0.165	3.4
		mg/kg	14.6	19.6	25
		mg/kg	0.15	0.22	0.6
		mg/kg	27.1	45.1	170
		mg/kg	85	82	250
		mg/kg	24	30	100
		mg/kg	30	30	190
		mg/kg	104	95	300
pH			HJ964-2018 D		
			GB15618 2018		

## 3.5-18

2023.09.16	pH	/	7.76	8.10	8.15	5.5-8.5
		mg/kg	0.135	0.107	0.164	3.4
		mg/kg	14.0	14.1	16.4	25
		mg/kg	0.10	0.14	0.20	0.6
		mg/kg	21.8	26.2	32.7	170
		mg/kg	91	83	84	250
		mg/kg	8	24	24	100
		mg/kg	19	25	27	190
		mg/kg	100	99	106	3.4
		mg/kg	456	459	431	1000
pH			HJ964-2018			D
GB15618 2018						

## 3.5-19

		112° 31 18.44 E		112° 31 48.61 E
		35° 10 05.01 N		35° 09 12.85 N
		0-0.5m	0.5-1.5m	1.5-3m
				0-0.2m
	%	30	15	5
				20
	mV	405	252	68
				412
	pH	8.02	8.00	8.01
				8.15
	cmol <sup>+</sup> /kg	6.7	7.4	6.4
				4.2
	mm/min	0.13	0.14	0.13
				0.13
	g/cm <sup>3</sup>	1.65	1.46	1.31
				1.60
	%	41.70	45.27	37.93
				39.96
	g/kg	0.4	0.4	0.4
				0.4
	g/kg	15.2	13.8	11.9
				16.1

6

GB36600-2018 1

GB15618-2018 1

GB15618-2018

1

pH 7.68-8.15

431-459mg/kg

HJ964-2018 D

### 3.5.6

2023 11 9-10

3.5-20

3.5-21

3.5-20

	B1		pH	1 HJ/T 20 HJ/T 298 (HJ 557-2010)
	B2			
	B3			
	B4			

3.5-21

mg/L pH

	0~0.2m	0.2~0.5m	0~0.2m	0.2~0.5m	0~0.2m	0.2~0.5m	0~0.2m	0.2~0.5m
pH	8.4	8.3	8.2	8.2	8.0	7.9	7.9	7.9
	0.05L	0.12	0.27	0.05L	0.10	0.05L	0.29	0.39
	0.04L	0.04L	0.09	0.04L	0.04L	0.04L	0.04L	0.05
	0.51	0.28	1.03	0.77	5.47	1.42	2.44	1.00
	1.42	0.38	1.08	0.87	2.33	0.93	1.76	0.98
	0.09L	0.09L	0.09L	0.09L	2.06	0.22	0.81	0.20
	1.12	0.27	0.73	0.51	1.15	0.61	1.97	0.46
	0.06L	0.06L	0.06L	0.06L	0.06L	0.06L	0.06L	0.06L
	0.79	2.96	0.67L	2.94	2.93	6.37	2.25	4.06
mg/L	0.26	0.25	0.21	0.23	0.31	0.28	0.21	0.24
mg/L	0.004L	0.004L	0.004L	0.004L	0.004L	0.004L	0.004L	0.004L

4.1

4.1.1

TSP

1

4.1-1

4.1-1

		TSP mg/m <sup>3</sup>							
		20m	50m	100m	150m	200m	250m		
		1.540	0.991	0.535	0.611	0.504	0.401	0.404	1.0
		1.457	0.963	0.568	0.570	0.519	0.411		
	/	1.498	0.977	0.552	0.591	0.512	0.406		
		0.943	0.577	0.416	0.424	0.417	0.420	0.419	
		1.105	0.647	0.453	0.420	0.421	0.417		
	/	1.024	0.612	0.435	0.422	0.419	0.419	/	/

4.1-1

20 200m

TSP 0.512 1.498mg/m<sup>3</sup>

50m

250m

TSP

20 200m

TSP 0.419 1.024mg/m<sup>3</sup>

20m

200m

TSP

20m

200m

115m

TSP

0.435mg/m<sup>3</sup>

2

1

3m

3m

"

100%

"

2

3m

"

100%

"

3

"

100%

"

4		360			
		"	100%	"	
5			"		100%
"					
6					
	"	100%	"		
7				"	1
			100%		"
8					
"			100%	"	

100m

200m

115

4.1.2

4.1.3

2.3-1

3m

13dB A

$$L_a = L_0 - 20Lg\left(\frac{r_a}{r_0}\right) - \Delta L$$

$L_a$                        $r_a$                       dB(A)

$L_0$                        $r_0$                       dB(A)

$L$

dB(A)

$r_0$

m

4.1-2

4.1-2

			dB	dB(A)				
				5m	10 m	50 m	100 m	200 m
1			83	71.0	65.0	51.0	45.0	39.0
2			65	51.0	45.0	31.0	25.0	19.0
3			70	56.0	50.0	36.0	30.0	24.0
4			83	71.0	65.0	51.0	45.0	39.0
				74.1	68.1	54.1	48.1	42.1

65-83dB(A)

5m

74.1dB(A)

10m

68.1dB(A)

50m

54.1dB(A)

100m

48.1dB(A)

10m

GB12523-2011

70dB(A)

GB12523-2011

70dB(A)

55dB(A)

115m

48.1dB(A)

4.1.4

1

951.1m  
19738.9m<sup>3</sup>

2

140kg/d

3655.4m  
67272.8m<sup>3</sup>

0.7kg/( d)

2704.3m  
47533.9m<sup>3</sup>

200

4.1.5

4.1.6

4.2

4.2.1

1

1

1

15

1

2.3.2

0.00171g/s

4.2-1

	/m		/m	/m	/m		/m	/h		g/s
	X	Y								
	38365150	3894560	225	84	70	22°	6	8760		0.00171

4.2-2

		0		m	m	m	m/s	(°C)	(h)		kg/h
											TSP
DA001		112° 31 9.7 7	35° 10 11. 96	229	15	0.3	40.50	25	8760		0.081

2

4.2-3

	1	0.9mg/m <sup>3</sup>	GB3095-2012 24h 3 1h
		80mg/m <sup>3</sup>	GB20426-2006
		10mg/m <sup>3</sup>	

3

HJ 2.2-2018

AERSCREEN

AERSCREEN

4.2-4

/		/	
			/
		/	42
		/	-18.5
			<input checked="" type="checkbox"/>
		/90m	/
			<input type="checkbox"/> <input checked="" type="checkbox"/>
		/km	/
		/°	/

4.2-5

		g/s	m	<sup>3</sup>	Pmax %
		0.00171	105	1.92	0.21
		0.0225	122	5.32	0.053

1      <sup>3</sup> 0.0019mg/m<sup>3</sup>

<sup>3</sup> 0.0053mg/m<sup>3</sup>

GB20426-2006

2

Y008

800m

4m/s

4m/s

4m/s

$$C = \frac{(1-Y)}{Y\sqrt{2} \times \sqrt{1+f} \times L^{2/3}} (N \cdot V \cdot Q/b)^{0.2527}$$

C— TSP mg/Nm<sup>3</sup>

N— /h

V— km/h

Q— g/m<sup>2</sup>

b— m

Y—

f— %

L— m

8 /h 20km/h

0.091kg/m<sup>2</sup>

2003—2004

0.017~0.091kg/m<sup>2</sup>

0.054kg/m<sup>2</sup>

6m

0.5

0.3

4.2-6

(m)	m	5.5	10	15	30	50	60	100	170
TSP (mg/m <sup>3</sup> )		1.29	0.87	0.66	0.42	0.30	0.26	0.19	0.13
		0.26	0.17	0.13	0.08	0.06	0.05	0.04	0.03
		1.445	1.025	0.815	0.575	0.455	0.415	0.345	0.285
		0.415	0.325	0.285	0.235	0.215	0.205	0.195	0.185
	GB3095 2012	TSP			0.30	0.155mg/m <sup>3</sup>			

170m

GB3095 2012

170m

1

15m

GB3095 2012

15m

200m

165m

50m

265

3

4

4. 2-7

									<input checked="" type="checkbox"/>
				5					=5km <input checked="" type="checkbox"/>
	SO <sub>2</sub> +NO <sub>x</sub>	<input type="checkbox"/>		500					
				(SO <sub>2</sub> NO <sub>2</sub> PM <sub>10</sub> PM <sub>2.5</sub> CO O <sub>3</sub> ) (TSP)					
				<input type="checkbox"/>					
					2022				
								<input checked="" type="checkbox"/>	
		AERMOD	ADMS	AUSTAL2000	EDMS/AEDT	CALPUFF			<input checked="" type="checkbox"/>
				5					= 5 km <input checked="" type="checkbox"/>
				( TSP )					PM <sub>2.5</sub> PM <sub>2.5</sub>
				C					C
				C					C
				C					C
	1h			h	C				C
				C					C

		k -		k -	
		TSP		<input checked="" type="checkbox"/>	
		VOCS			<input checked="" type="checkbox"/>
		m			
		SO <sub>2</sub> : 0 t/a	NO <sub>x</sub> : 0 t/a	: 0.23 t/a	VOCS: 0.011 t/a

## 4.2.2

### 4.2.2.1

#### 1

13128m<sup>3</sup>/d

SS COD

860m<sup>3</sup>/h

IV

GB5084-2021

550m<sup>3</sup>/d

14m<sup>3</sup>/d

40m<sup>3</sup>/d

12524m<sup>3</sup>/d

300m

2.8km

13128 m<sup>3</sup>/d

0.152 m<sup>3</sup>/s

604m<sup>3</sup>/d

12524m<sup>3</sup>/d 0.145m<sup>3</sup>/s

552m<sup>3</sup>/h

547m<sup>3</sup>/h

1%

2

12524 m<sup>3</sup>/d 0.145 m<sup>3</sup>/s

COD416.17mg/L 0.756mg/L

3

300m +2.8km

13km

4.2-8

1		COD SS NH <sub>3</sub> -N			TW001			DW001		
2		COD SS NH <sub>3</sub> -N			TW002			DW002		

4.2-9

						t/a				
1	DW001	112° 3 1 15. 89	35° 9 53.6 8			457.13		III	112° 32 58.88	35° 09 2 9.59

2	DW002	112° 3 1 15. 53	35° 10 6.56			0.24		III	112° 32 59.68	35° 09 3 0.78
GB20426-2006 GB3838-2002 IV										

4.2-10

										mg/L
1	DW001		COD							30
										1.5
GB3838-2002 IV										

4.2-11

			mg/L	t/d	t/d	t/a	t/a	
1	DW001	COD	14.67	0	0.1855	0	67.04	
			0.23	0	0.0029	0	1.05	
		COD					0	67.08
						0	1.06	

4.2.2.2

(HJ2.3-2018)

1

300m+2.8km

13km

3.0km

IV

2

COD

3

GB/T25173-2010

15m<sup>3</sup>/s

$$C = \frac{(C_p Q_p + C_h Q_h)}{(Q_p + Q_h)}$$

$$C \text{---} \text{mg/L}$$

$$C_p \text{---} \text{mg/L}$$

$$Q_p \text{---} \text{m}^3/\text{s}$$

$$C_h \text{---} \text{mg/L}$$

$$Q_h \text{---} \text{m}^3/\text{s}$$

O Connor

Pe

$$\alpha = \frac{kE_x}{u^2}$$

$$Pe = \frac{uB}{E_x}$$

0.027 Pe 1

$$C = C_0 \exp\left(-\frac{kx}{u}\right) \quad x \geq 0$$

0.027 Pe < 1

$$C = C_0 \exp\left(\frac{ux}{E_x}\right) \quad x < 0$$

$$C = C_0 \exp\left(-\frac{kx}{u}\right) \quad x \geq 0$$

$$C_0 = (C_p Q_p + C_h Q_h) / (Q_p + Q_h)$$

0.027 < 380

$$C(x) = C_0 \exp\left[\frac{ux}{2E_x} (1 + \sqrt{1 + 4\alpha})\right] \quad x < 0$$

$$C(x) = C_0 \exp\left[\frac{ux}{2E_x} (1 - \sqrt{1 + 4\alpha})\right] \quad x \geq 0$$

$$C_0 = (C_p Q_p + C_h Q_h) / \left[ (Q_p + Q_h) \sqrt{1 + 4\alpha} \right]$$

>380

$$C = C_0 \exp\left(x \sqrt{\frac{k}{E_x}}\right) \quad x < 0$$

$$C = C_0 \exp\left(-x \sqrt{\frac{k}{E_x}}\right) \quad x \geq 0$$

$$C_0 = (C_p Q_p + C_h Q_h) / (2A \sqrt{k E_x})$$

Ex

El der

$$Ex = 5.93H(gHI)^{1/2}$$

—0 Connor

1

Pe—

1

$E_x$ —		$m^2/s$
$k$ —		$1/s$
$B$ —	$m$	
$H$ —	$m$	
$l$ —		
$u$ —	$m/s$	
$g$ —	$m/s^2$	
$C$ —	$mg/L$	
$C_0$ —		$mg/L$
$x$ —	$m \quad x=0$	$x \quad 0$

4.2-12

	1/d	
	COD	
~	0.18~0.25	0.15~0.20
~	0.10~0.18	0.10~0.15
	0.05~0.10	0.05~0.10

IV

COD

COD $0.15d^{-1}$        $0.12d^{-1}$

$0.524m^3/s$

4.2-13

m		6
m		0.8
		1/240
m/s		0.16
m <sup>3</sup> /s		0.524
E <sub>x</sub> m <sup>2</sup> /s		0.8574
k 1/d	COD	0.15
		0.12

COD =0.000058 Pe=1.12 COD

=0.000047 Pe=1.12

4

12524

m<sup>3</sup>/d

COD416.17mg/L

0.756mg/L

5

**4.2-13**

	m <sup>3</sup> /s	COD	
		mg/L	mg/L
	0.1450	416.17	0.756

500m

4.2-14	200m	500m
		500m
	m <sup>3</sup> /s	0.350
	COD mg/L	13
	mg/L	0.222

6

4.2-15			mg/L		
		COD	131.09	30	
			0.38	1.5	

GB3838-2002 IV

COD

GB3838-2002 IV

8000m<sup>3</sup>

2

1320 m<sup>3</sup>

14h

2h

7

GB3838-2002

4.2.2.3

4.2-16

4.2-16

				<input checked="" type="checkbox"/>	
		<input checked="" type="checkbox"/>			
		<input checked="" type="checkbox"/> pH			
		<input checked="" type="checkbox"/>			
				<input checked="" type="checkbox"/>	
		<input checked="" type="checkbox"/>		<input checked="" type="checkbox"/>	
		<input checked="" type="checkbox"/>		<input checked="" type="checkbox"/>	
		<input checked="" type="checkbox"/>		BOD <sub>5</sub>	pH
			<input checked="" type="checkbox"/>	CODcr	3
		3.0km		km <sup>2</sup>	
		pH	CODcr	BOD <sub>5</sub>	
		I	II	III	IV
					<input checked="" type="checkbox"/>
		<input checked="" type="checkbox"/>			
				<input checked="" type="checkbox"/>	<input checked="" type="checkbox"/>
				<input checked="" type="checkbox"/>	<input checked="" type="checkbox"/>
					<input checked="" type="checkbox"/>

		3.0 km		km <sup>2</sup>
		COD		
				<input checked="" type="checkbox"/>
		<input checked="" type="checkbox"/>	<input checked="" type="checkbox"/>	<input checked="" type="checkbox"/>
				<input checked="" type="checkbox"/>
				<input checked="" type="checkbox"/>
				(t/a)
		COD NH <sub>3</sub> -N	15.28 1.21	mg/L
				(t/a)
				mg/L
		m <sup>3</sup> /s	m <sup>3</sup> /s	m <sup>3</sup> /s
		m <sup>3</sup> /s	m <sup>3</sup> /s	m <sup>3</sup> /s
		<input checked="" type="checkbox"/>		
				<input checked="" type="checkbox"/> <input checked="" type="checkbox"/>
			0	
				pH COD
				BOD5 COD pH

## 4.2.3

### 4.2.3.1

1.

1

K=10.82-42.9m/

206.4-226.7m

2

80m

20-60m K=0.01-7.9m/

+165.98-225.37m

HCO<sub>3</sub>C-Na· Mg

5m<sup>3</sup>/h

10m<sup>3</sup>/h

3

17.1m

0.16-0.64m/

+160.28-+225.40m

4

580m

1984

80m<sup>3</sup>/

+145.25m, 69

K=0.00047m/

56

2.

4.2-17

1	40 75m
2	20 65m
1	
3	26.72 60.14m

4	80m
	580m

3.

1

1. 51L/s· m

2

1

3

$L_8$

$L_8$

1

$L_8$

1

8m

4 L<sub>2</sub>  
 L<sub>2</sub> 1 80m 9.76 10.72m  
 0.6912L/s  
 +160.42 181.7m 0.0445 0.0838m/d 1

5 1  
 300m 1 90m  
 1 1

6

7

1 11 +45m-+104m  
 1979 6 -1991 1 543750m<sup>2</sup>  
 10 20 m<sup>3</sup>/h +25m  
 11 11

2 15 -50m-+25m

1992 1 — 325000m<sup>2</sup> 259.5m  
123m 31920m<sup>2</sup> 0.1 3192m<sup>3</sup>

3 12 -36m-+55m  
2001 4 — 691500m<sup>2</sup> 240.5m  
440.7m 106007m<sup>2</sup> 0.1 10601m<sup>3</sup>  
12

8  
1

X 3895696.432 Y  
38364584.065 Z: 252.441 X 3895808.059 Y 38364603.487  
Z: 256.00 1991 10 9 / 2005

0.3776km<sup>2</sup> 1 175 20m  
15 / +55m  
25m<sup>3</sup>/h 30m<sup>3</sup>/h  
729m<sup>3</sup>, 3 110KW  
MD85-45×6 125mm

2019 11

6 11011 18600 2013  
11013



0.8786km<sup>2</sup>,

1 50m -150m 140m<sup>3</sup>/h

280m<sup>3</sup>/h

2016 10

21061

2007

9 —2012 4 14588

21061

21071

2012 10 —2013 11

22827m<sup>2</sup>

4m<sup>3</sup>/h

21051

21071

4

X

3893836.320 Y 3836716.357 Z 195.5

X 3893824.749, Y

38365705.156 Z 198.6 2009

15 / 1

+105m

40m<sup>3</sup>/h,

80m<sup>3</sup>/h

0.2m<sup>3</sup>/mi n

2009 7

2009 4

1995 8 —2009 3

52320m<sup>2</sup>

12

12 2019 2  
 12  
 5 2019 4 16 12  
 358m 2 7  
 1 3 2  
 1.5m<sup>3</sup>/h 0.2m  
<sup>3</sup>/h  
 2019 9 25 12211 1  
 7 1 4 2  
 1.7m<sup>3</sup>/h  
 0.2m<sup>3</sup>/h  
 2019 4 16 12211 218m 3  
 5 1 3 2  
 1.7m<sup>3</sup>/h  
 4 5  
 5  
 X 3894282.98 Y  
 38366719.52 Z 223.5 X 3894305.86 Y 38366630.5  
 Z 221.8 1997 7 1998 10 1  
 +152m +80m +106m  
 15 / 2018 10

40m<sup>3</sup>/h                      60m<sup>3</sup>/h  
511.4m<sup>3</sup>,                      3    MD85-45× 3                      55KW  
133mm

21    21022    2013  
1 —2014    8    30000m<sup>2</sup>

9m<sup>3</sup>/h  
21032    2014    7    —2014    8  
2400m<sup>2</sup>    ,  
4.

579m<sup>3</sup>/h    1000m<sup>3</sup>/h    547m<sup>3</sup>/h,  
5.

4.2-1

4.2-2

地 层					分 层 厚	累 厚	岩 性 柱 状 1:5000	岩 性 描 述	备 注	
界	系	统	组	段						
新生界	第四系				5	5		黄土、粘土、砂质粘土、卵石、胶结砾石。		
	第三系				75	80		粘土、砂质粘土、卵石、胶结粗砾石及砾岩。		
古 生 界	二叠系	上统	上段		45	125		以厚层状紫灰、灰绿色砂质泥岩、泥岩为主，夹薄层细砂岩。		
			中段		29.81	154.81		以厚层状紫灰、灰绿色砂质泥岩、泥岩为主，夹薄层细砂岩。		
			下段		20	174.81		以中-粗粒砂岩为主，夹灰绿色砂质泥岩。		
	下统	下石盒子组			70	244.81		上部为紫色花斑、中下部浅灰、灰色粉砂岩、砂质泥岩，具鲕状结构，底部为中砂岩		
		山西组			87	331.81		灰、灰黑色泥岩、砂岩。含煤2-5层，二1层可采，含大量植物化石。	主要含煤地层，其中大煤(2#)平均厚度5.05m。	
	石炭系	上统	太原组			68	399.81		灰、灰黑色泥岩、灰岩及砂岩。含煤层12层，灰岩6-8层，富含动、植物化石。	
		中统	本溪组			16	415.81		深灰色粉砂岩、灰或紫红色铝土岩。含不稳定煤层1-2层、不可采	
	奥陶系	中统				>200		豹皮状灰岩，纯灰岩与白云质角砾状灰岩互层		

图 4.2-2 矿区综合地质柱状图

4.2.3.2

4.2.3.3

1

$$L = \frac{K \times I \times T}{n_e}$$

L m

K m/d

I

T d

$n_e$

2

2

K

K=10.82-42.9m/d

206.4-226.7m

HJ610-2016 B

K 26m/d

I

I

0.0177

**4.2-18**

		m	m	m	
		+203	2770	24	0.0087
		+179			

T 5000d

$n_e$

$n_e$  0.4

3

4.2-4

		K(m/d)		(d)	$n_e$	L
	2	26	0.0087	5000	0.4	5632

5632m

2816m

4.2-3

4.2.3.4

1.5.1

1970

1976

30

30 m<sup>3</sup>

3.5.3

2.5

1 t

4.2.3.5

1

$$H_{Li} = \frac{100 \sum M}{1.6 \sum M + 3.6} + 5.6 \quad m$$

$$H_{Li} \quad m$$

$$M \quad m$$

$$1 \quad 3 \quad 7m \quad 4.25m$$

$$H_{i\max} = (100 \times 7) / (1.6 \times 7 + 3.6) + 5.6 = 52.89m$$

2

1

52.89m

4.8 55.40m

100 210m

45 200m

1

1

2

1

1

20-60m K=0.01-7.9m/d +165.98-225.37m

HCO<sub>3</sub>C-Na· Mg

5m<sup>3</sup>/h

10m<sup>3</sup>/h

1

1

1

1

1

1

1

4.2.3.6

1

200-300m

2

“ ”

#### 4.2.3.7

-

GB5085.3-2007

GB8978-1996 1 4

GB18599-2020

GB/T14848-2017 III

#### 4.2.4

##### 4.2.4.1

200m

200m

115m

200m

4.2.4.2

4.2-18      4.2-19

4.2-18 工业场地室外噪声源强调查清单

			/m			/ dB	/dB A		
			X	Y	Z				
1		FBCDZNo.20/2×90	185	184	0.5	92/1	100		24h
2		FBCDZNo.20/2×90	191	186	0.5	92/1	100		24h

4.2-19 工业场地室内噪声源强调查清单

						/m			/m	/dB A		/dB A	/dB A		
			/ dB A	/dB A		X	Y	Z							
1			SRC-150S A	95/1	103		-12	115	0.5	2.0	89	8h	15	74	1.0
2			2JK-3× 1.5E	90/1	98		-73	80	0.5	2.0	84	18h	15	69	1.0
3			2JK-3× 1.5E	90/1	98		-28	91	0.5	2.0	84	24h	15	69	1.0



EIA2.0

4.2-4

4.2-22

表 4.2-22 采取降噪措施后厂界噪声预测结果表 单位: dB (A)

	dB(A)								
	45	68	<40	<40	44	59	<45	60	50

4.2-22

(GB12348-2008)2

60dB(A)

50dB(A)

200

20 dB(A)

100m

10 dB(A)

3

60

75dB(A)

800m

Y008

12m

200m

8 /h

4.2.5

1

1 t/a

1 /

Bq/g

2

58.3t/a

3

450t/a

4

3.5t/a

" "

5

4.3

HJ169-2018

HJ169-2018

4.3.1

1

HJ 619-2011

"

"

HJ/T169-2018

B

"

"

2

(HJ169-2018)

P

B

Q

$$Q = \frac{q_1}{Q_1} + \frac{q_2}{Q_2} + \dots + \frac{q_n}{Q_n}$$

q1 q2 ... qn

t

Q1 Q2 ... Qn

t

Q 1

Q

1

10

2

100

3

4.3-1

	q <sub>n</sub> t			Q <sub>n</sub> t	Q
		/			
	10	/	10	2500	0.00816
	0.10	/	0.10	2500	0.000072
	2	/	2	2500	0.00136
	50	/	50	2500	0.0408
	0.5	/	0.5	2500	0.0002
					0.400662

q/Q<1

3

HJ/T169-2018

4.3-2

4.3-2

	+			
				a
a				A

4.3.2

1.7-1

4.3.3

1

HJ 169-2018

B

4.3-3

4.3-3

1			+	+

2

1

2

3

4

CO

4.3-4

1					
2		NH <sub>3</sub> -N CODcr			
3		NH <sub>3</sub> -N CODcr			

4.3.4

4.3.4.1

#### 4.3.4.2

1

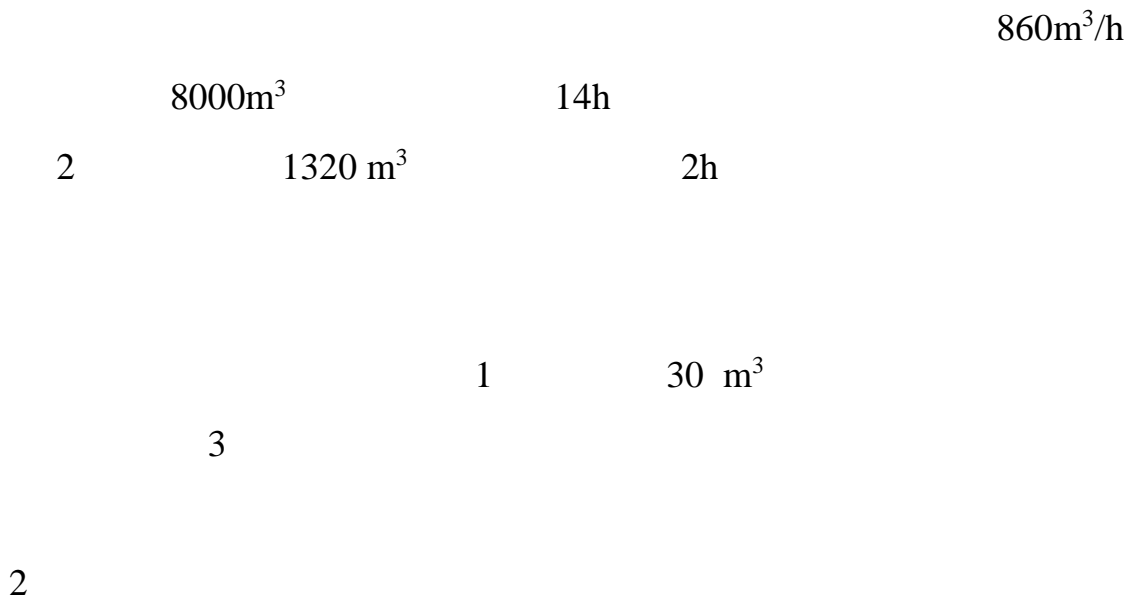

#### 4.3.5

##### 4.3.5.1

1

1

2

3

80m<sup>2</sup>

4

2

1

2

4.5m<sup>3</sup>

3

3

4

5

6

4.3.5.2

1

1320m<sup>3</sup>

2

3

4

4.3.5.3

1

2

3

4.3.6

**4.3-5**

		112°31' 11.72"		35°10' 08.77"
	1			
	1			
	2			
	3	80m <sup>2</sup>		
	4			

	2 1  2  3	4.5m <sup>3</sup>

5.1

5.1.1

6

5.1-1

5.1-1

5.1-1

1			
2			
3			
4			
5			
6			

1

400kg 800kg

450kg 550kg

250kg 350kg

2

10

12cm

10m

3

4

5

## 5.1.2

1

2

1

2

3

4

5

5.1-2

5.1-3

5.1.3

40

5.1.4

10

5.1-2

5.1-4

5.1-2

	hm <sup>2</sup>		
	402.40	75.01	
	71.71	13.37	
	74.57	13.90	
	1.92	0.36	
	25.08	4.67	
	8.66	1.61	
	44.68	8.33	
	102.40	19.09	
	12.09	2.25	
	1.23	0.23	
	744.73	138.82	

## 5.1.5

7 8

9

2016-2030

2016-2030

2017 2

500t/km<sup>2</sup>. a

## 5.1.6

1

10

2

6

3

5

76.08%

4

5

6

5.2

5.2.1

2.0hm<sup>2</sup>

5.2.2

1

2

5.3

5.3.1

1

$$W(x) = \frac{M_{cm}}{\sqrt{\pi}} \int_{-\sqrt{\pi} \frac{x}{r}}^{\infty} e^{-\lambda^2} d\lambda (mm)$$

$$i(x) = \frac{W_{cm}}{r} e^{-\pi(\frac{x}{r})^2} (mm/m)$$

$$K(x) = 2\pi \frac{W_{cm}}{r^2} \left(-\frac{x}{r}\right) e^{-\pi(\frac{x}{r})^2} (10^{-3}/m)$$

$$U(x) = b \times W_{cm} \times e^{-\pi(\frac{x}{r})^2} (mm)$$

$$\varepsilon_{(x)} = 2\pi b \times \frac{W_{cm}}{r} \left(-\frac{x}{r}\right) e^{-\pi(\frac{x}{r})^2} (mm/m)$$

2

$$W_{(x)} = \frac{W_{cm}}{\sqrt{\pi}} \left( \int_{-\sqrt{\pi} \frac{x}{r}}^{\infty} e^{-\lambda^2} d\lambda - \int_{-\sqrt{\pi} \frac{x-L}{r}}^{\infty} e^{-\lambda^2} d\lambda \right) (mm)$$

$$i_{(x)} = \frac{W_{cm}}{r} \left( e^{-\left(\sqrt{\pi} \frac{x}{r}\right)^2} - e^{-\left(\sqrt{\pi} \frac{x-L}{r}\right)^2} \right) (mm/m)$$

$$K_{(x)} = -2\pi \frac{W_{cm}}{r^2} \left( \frac{x}{r} e^{-\left(\sqrt{\pi} \frac{x}{r}\right)^2} - \frac{x-L}{r} e^{-\left(\sqrt{\pi} \frac{x-L}{r}\right)^2} \right) (10^{-3}/m)$$

$$U_{(x)} = b \times W_{cm} \left( e^{-\left(\sqrt{\pi} \frac{x}{r}\right)^2} - e^{-\left(\sqrt{\pi} \frac{x-L}{r}\right)^2} \right) (mm)$$

$$K_{(x)} = -2\pi \frac{W_{cm}}{r^2} \left( \frac{x}{r} e^{-\left(\sqrt{\pi} \frac{x}{r}\right)^2} - \frac{x-L}{r} e^{-\left(\sqrt{\pi} \frac{x-L}{r}\right)^2} \right) (mm/m)$$

3

y x r<sub>1</sub> r<sub>2</sub> r

4

$$W_{cm}$$

$$i_{cm} = \frac{W_{cm}}{r} (mm/m)$$

$$K_{cm} = \pm 1.52 \frac{W_{cm}}{r^2} 10^{-3}/m$$

$$U_{cm} = b \cdot W_{cm} (mm)$$

$$w_{cm} = \pm 1.52 b \frac{W_{cm}}{r} \text{ (mm/m)}$$

b

q  
(S)

5.3-1

	H m		m	q	P	D 0.0032P * 1-0.0038		=90° -0.68*
	120 200	5° 12°	4.25	0.80	0.70	2.0	0.3	86.6° 87.96
	P 0.70 D 2.00							

5.3.2

1

1

5.3-1~5.3-5

0.80km<sup>2</sup>

5.3-2

### 5.3-2

	(mm)	(mm/m)	(10 <sup>-3</sup> /m)	(mm)	(mm/m)
	0 3397	-44.6 47.1	-1.42 1.05	-972 941	-29.22 20.69

### 5.3.3

$$T = \frac{12}{8 \sim 2) \times V} \times H_0$$

T

H<sub>0</sub>

m

V

m/a

150 240m

190m

634m/a

5.3-3

### 5.3-3

m	150	170	190	210	230	250
	0.35	0.40	0.45	0.50	0.54	0.59
	1.42	1.61	1.80	1.99	2.18	2.37

### 5.3.4

1

0 3397mm

20m

5.3-4

2017 5

5.3-4

		mm/m	K 10 <sup>-3</sup> /m	I mm/m		
	1 2mm	2.0	0.2	3.0		
	4mm					
	10mm					
	15mm 30mm	4.0	0.4	6.0		
	1/3 20mm 1/2					
	30mm					
	50mm	6.0	0.6	10.0		
	1/2 50mm					
	50mm					
	30mm	6.0	0.6	10.0		
	50mm					
	50mm					
	60mm					

	25mm					
	25mm 60mm					

5.3.5

5.3.6

950

5.3.7

Y008

Y008

440m

5.4

5.4.1

HJ964-2018

5.4.2

3.5.5

1976

47

### 5.4.3

	$1.0 \times 10^{-8} \text{cm/s}$	1.5m	
			C30
P6		P6	
$0.339 \times 10^{-8} \text{cm/s}$	1		
	1		
GB36600-2018	1		
GB15618-2018	1		

5.4.4

1

GB/36600-2018

GB15618-2018

2

$1.0 \times 10^{-7}$  cm/s

1.5m

土壤环境影响评价自查表

表 5.4-6

		<input checked="" type="checkbox"/>			
		<input checked="" type="checkbox"/>			
		23 hm <sup>2</sup>			
		<input checked="" type="checkbox"/>			
		-			
		-			
		<input checked="" type="checkbox"/>			
		<input checked="" type="checkbox"/>			
		<input checked="" type="checkbox"/>			
		a <input checked="" type="checkbox"/> b <input checked="" type="checkbox"/> c <input checked="" type="checkbox"/> d			
		5.4-5			
					3.5-1
		6	3	0~20cm	
		3	6	0~3m	
		GB36600-2018 1 45			



## 6.1

### 6.1.1

1		3m		"		100%
"						
2						
3m						
"		100%	"			
3						
		"		100%		"
4						
		"		100%	"	
5				"		100%
"						
6						
"	"	100%	"			
7					"	1
				100%		"
8						
"				100%	"	

### 6.1.2

6.1.3

3m

6.1.4

**6.2**

6.2.1

1

1

1

2

1

3

## 6.2.2

1

2

6

+1

+

2

3

300m+2.8km

## 6.2.3

200

20 dB(A)

100m

10 dB(A)

## 6.2.4

1

1 t/a

2

58.3t/a

3

450t/a

4

3.5t/a

" "

## 6.3

### 6.3.1

100%

### 6.3.2

1 t/a

100%

4km<sup>2</sup>

2.5 t

### 6.3.3

2021

[2021]70

1.21m<sup>3</sup>/t

1.22m<sup>3</sup>/min

2019

[2019]53

1.15m<sup>3</sup>/t

1.01m<sup>3</sup>/min

## 6.4

### 6.4.1

1

1

2

2

1

2

3

4

5

3

1

2

## 6.4.2

( ) HJ 651 2013

1

2

3

4

100%

5

6

7

8

9

10

1.5%

11

12

Y008

"

"

13

14

"

"

15

16

6.4.3

## 6.4.4

6.4-1

							( )
		0.80km <sup>2</sup>	0.80km <sup>2</sup>		/		
		23hm <sup>2</sup>	23hm <sup>2</sup>		2030 12		30

## 6.5

6.5-1

177

6.5-1

					( )
				(GB8978-1996) 4	20
			3m		5
			3m		

			100		
					10
					1
			3m		2
				GB12523-2011	0
					100
					3.0
				100%	5.0
		"	"		
				(GB8978-1996)	/
				4	
					1
					147
		1			
			2		
			3		
			4		

		5		
		6		
		7		
		8		
		860m <sup>3</sup> /h		
		+ +		
		2 1		
		+1		
		150m <sup>3</sup>	(GB20426 2006)	
			1 2	
		105m <sup>3</sup> /h	(GB8978-1996)	
			4	
			100%	
			100%	
			100%	
		" "	100%	
			100%	
			(GB20426 2006)	
			5	
		1	(GB20426 2006)	
			5	

			15%	
				30
				177

## 6.6

### 6.6-1

#### 6.6-1

				( )
			(GB8978-1996) 4	20
		3m		
		3m		5
		100		
				10

				0.5
		3m	GB12523-2011	2
				0
				100
				3.0
		" "	100%	5.0
			(GB8978-1996) 4	/
				1
				147

## **7.1**

### 7.1.1

### 7.1.2

## **7.2**

### 7.2.1

1

2

3

4

177

7.2.2

## 8.1

### 8.1.1

### 8.1.2

1

2 4

2

1

2

3

4

5

6

7

8

9

10

8.1.3

8.1-1

8.1-1

	1. 2. 3. 4.
	1. 2. 3. 4.
	1. 2.  3.  4.  5. 6.
	1. 2. 3. 4. 5. 6.
	1. 2.  3.  4.  5.

## 8.1.4

## 8.2

### 8.2-1

8.2-1

			3 1 /	GB20426-2006 4 5
		pH BOD <sub>5</sub> COD	pH COD 1 /	GB50426-2006 1 2 DB41/ 2087 2021 2 3 4 (GB3838-2002)
	1m		1 / 2	GB12348-2008 2
		pH Ca <sup>2+</sup> Mg <sup>2+</sup> CO <sub>3</sub> <sup>2-</sup> HCO <sub>3</sub> <sup>-</sup> Cl <sup>-</sup> SO <sub>4</sub> <sup>2-</sup> K <sup>+</sup> Na <sup>+</sup>	1 /	GB/T14848-2017
	500m	pH SS COD <sub>cr</sub> BOD <sub>5</sub> Cd Cr <sup>6+</sup>		GB3838-2002
		pH	1 /	

				(GB36600-2018)

## 8.3

### 8.3.1

1

2

2

COD NH<sub>3</sub>-N

3

### 8.3.2

1

2

3

### 8.3.3

1

1

15562.1-1995

GB15562.2-1995

2









2m

2

1

2

8.3-1

1				
2				
3				
4				
				

9.1

9.1.1

5.2787km<sup>2</sup>

66 t/a

217.7 t 1.3

2.5a

+25m

12

12

23hm<sup>2</sup>

20601.99

177

(2019 )



9.1.3

1

1

2

TSP

3

140kg/d

4

72dB A

82dB A

2

1

457.13 m<sup>3</sup>/a

2

TSP

3

1 t/a

58.3t/a

450t/a

3.5t/a

4

60dB A

80dB A

9.1.4

**9.1.4.1**

1

1

3m

"

100%

"

2

3m

"

100%

"

3

	"		100%	"
4				
	"		100%	"
5			"	100%
"				
6				
	"	100%	"	
7				" 1
			100%	"
8				
"			100%	"
2				

3

3m

4

### 9.1.4.2

1

1

1

1

2

1

3

2

1

+ +

2

6

2

3

300m+2.8km

13km

3

1

2

3

4

5

6

7

4

1

2

58.3t/a

3

450t/a

4

3.5t/a

“ ”

9.1.5

9.1.6

177

9.1.7

1

2

ISO14001

3

9.2

1

2

3

4

9.3